

ENGINEERING DRAWING

(NSQF)

1st YEAR
(For 2 Year Trades)

(As per Revised Syllabus July 2022)

Group 20

Group 20 CTS Trades Covered

Instrument Mechanic, Tech. Medical Electronics, Technician Mechatronics,
Technician Power Electronics System, Electronics Mechanic,
Mechanic Consumer Electronics Appliances,
Tech. Electronic System Design & Repair



Directorate General of Training

DIRECTORATE GENERAL OF TRAINING
MINISTRY OF SKILL DEVELOPMENT & ENTREPRENEURSHIP
GOVERNMENT OF INDIA



**NATIONAL INSTRUCTIONAL
MEDIA INSTITUTE, CHENNAI**

Post Box No. 3142, CTI Campus, Guindy, Chennai - 600 032

Engineering Drawing (NSQF) 1st Year (For 2 Year Trades)

Group 20 Engineering Trades

As per Revised syllabus July 2022 under CTS

Developed & Published by



National Instructional Media Institute

Post Box No.3142

Guindy, Chennai - 600032

INDIA

Email: chennai-nimi@nic.in

Website: www.nimi.gov.in

Copyright © 2022 National Instructional Media Institute, Chennai

First Edition : September 2022

Copies : 1000

Rs.75/-

All rights reserved.

No part of this publication can be reproduced or transmitted in any form or by any means, electronic or mechanical, including photocopy, recording or any information storage and retrieval system, without permission in writing from the National Instructional Media Institute, Chennai.

FOREWORD

The Government of India has set an ambitious target of imparting skills to 30 crores people, one out of every four Indians, by 2020 to help them secure jobs as part of the National Skills Development Policy. Industrial Training Institutes (ITIs) play a vital role in this process especially in terms of providing skilled manpower. Keeping this in mind, and for providing the current industry relevant skill training to Trainees, ITI syllabus has been recently updated with the help of comprising various stakeholder's viz. Industries, Entrepreneurs, Academicians and representatives from ITIs.

The National Instructional Media Institute (NIMI), Chennai, has now come up with instructional material to suit the revised curriculum for **Engineering Drawing 1st Year (For 2 Year Trades) NSQF Group 20 Engineering Trades (Revised 2022)** under CTS will help the trainees to get an international equivalency standard where their skill proficiency and competency will be duly recognized across the globe and this will also increase the scope of recognition of prior learning. NSQF trainees will also get the opportunities to promote life long learning and skill development. I have no doubt that with NSQF the trainers and trainees of ITIs, and all stakeholders will derive maximum benefits from these IMPs and that NIMI's effort will go a long way in improving the quality of Vocational training in the country.

The Executive Director & Staff of NIMI and members of Media Development Committee deserve appreciation for their contribution in bringing out this publication.

Jai Hind

New Delhi - 110 001

SHRI. ATUL KUMAR TIWARI., I.A.S.,
Secretary
Ministry of Skill Development & Entrepreneurship,
Government of India.

PREFACE

The National Instructional Media Institute(NIMI) was set up at Chennai, by the Directorate General of Training, Ministry of skill Development and Entrepreneurship, Government of India, with the technical assistance from the Govt of the Federal Republic of Germany with the prime objective of developing and disseminating instructional Material for various trades as per prescribed syllabus and Craftsman Training Programme(CTS) under NSQF levels.

The Instructional materials are developed and produced in the form of Instructional Media Packages (IMPs), consisting of Trade Theory, Trade Practical, Test and Assignment Book, Instructor Guide, Wall charts, Transparencies and other supportive materials. The above material will enable to achieve overall improvement in the standard of training in ITIs.

A national multi-skill programme called SKILL INDIA, was launched by the Government of India, through a Gazette Notification from the Ministry of Finance (Dept of Economic Affairs), Govt of India, dated 27th December 2013, with a view to create opportunities, space and scope for the development of talents of Indian Youth, and to develop those sectors under Skill Development.

The emphasis is to skill the Youth in such a manner to enable them to get employment and also improve Entrepreneurship by providing training, support and guidance for all occupation that were of traditional types. The training programme would be in the lines of International level, so that youths of our Country can get employed within the Country or Overseas employment. The **National Skill Qualification Framework (NSQF)**, anchored at the National Skill Development Agency(NSDA), is a Nationally Integrated Education and competency-based framework, to organize all qualifications according to a series of **levels of Knowledge, Skill and Aptitude**. Under NSQF the learner can acquire the Certification for Competency needed at any level through formal, non-formal or informal learning.

The **Engineering Drawing** 1st Year (For 2 Year Trades) NSQF Group 20 - Engineering Trades (Revised 2022) under CTS is one of the book developed by the core group members as per the NSQF syllabus.

The **Engineering Drawing** 1st Year (For 2 Year Trades) NSQF Group 20 - Engineering Trades under (Revised 2022) CTS as per NSQF is the outcome of the collective efforts of experts from Field Institutes of DGT, Champion ITI's for each of the Sectors, and also Media Development Committee (**MDC**) members and Staff of **NIMI**. NIMI wishes that the above material will fulfill to satisfy the long needs of the trainees and instructors and shall help the trainees for their Employability in Vocational Training.

NIMI would like to take this opportunity to convey sincere thanks to all the Members and Media Development Committee (MDC) members.

Chennai - 600 032

EXECUTIVE DIRECTOR

ACKNOWLEDGEMENT

The National Instructional Media Institute (NIMI) sincerely acknowledge with thanks the co-operation and contribution of the following Media Developers to bring this IMP for the course **Engineering Drawing 1st Year (For 2 Year Trades) Group 20 - Engineering Trades** as per NSQF Revised 2022.

MEDIA DEVELOPMENT COMMITTEE MEMBERS

Shri. M. Sangara pandian	-	Training Officer (Retd.) CTI, Govt. of India, Guindy, Chennai - 32.
Shri. G. Sathiamoorthy	-	Jr. Training Officer - SG (Retd.) Govt. I.T.I., Trichy, DET - Tamilnadu.
Shri. R. N. Krishnasamy	-	Vocational Instructor (Retd.) MDC Member, NIMI, Chennai - 32.
Shri. D. S. Varadarajulu	-	DD/Principal (Retd), Govt. I.T.I., Ambattur, Chennai.
Shri. C.C. Subramanian	-	Training Officer (Retd.) Balamandir PHMITI, Chennai - 17.

NIMI CO-ORDINATORS

Shri. Nirmalya Nath	-	Deputy General Manager, NIMI, Chennai - 32.
Shri. G. Michael Johny	-	Manager, NIMI, Chennai - 32.

NIMI records its appreciation of the **Data Entry, CAD, DTP Operators** for their excellent and devoted services in the process of development of this IMP.

NIMI also acknowledges with thanks, the efforts rendered by all other staff who have contributed for the development of this book.

INTRODUCTION

Theory and procedure along with the related exercises for further practice

This book on theory and procedure along with related exercises contains theoretical information on **1st Year Engineering drawing** NSQF (For 2 Year Revised syllabus July 2022 Group 20 - Engineering Trades) and procedure of drawing/ sketching different exercise for further practice are also available. Wherever required, BIS specification has been used.

Exercise for further practice

The practice exercise is given with Theory and procedure for 1st Year book made obsolete as it was felt that, it is very difficult to work in workbook using drawing instruments. It is well known fact that, any drawing is prepared on suitable standard size of drawing sheets only.

The instructor is herewith advised to go through the instructions given below and to follow them in view of imparting much drawing skill in the trainees.

Acquiring the above said ability and doing small drawings is not a simple task. These books will provide a good platform for achieving the said skills.

Time allotment:

Duration of 1st Year : 40 Hrs

Sl. No.	Topic	Exercise No.	Time Allotment
1	Introduction to Engineering Drawing and Drawing Instruments	1.1.01 - 1.1.05	2
2	Free hand drawing	1.2.06 - 1.2.08	6
3	Drawing of Geometrical Figures	1.3.09 - 1.3.12	4
4	Symbolic Representation	1.4.13	4
5	Reading of Electronic Circuit Diagram	1.5.14	14
6	Reading of Electronic Layout drawing	1.6.15	10
			<hr/> 40 Hrs <hr/>

Instructions to the Instructors

It is suggested to get the drawing prepared on A4/A3 sheets preferably on only one side. If separate table and chair facility is available for every trainee then it is preferred to use A3 sheets and if the drawing hall is provided with desks then A4 sheets may be used. However while preparing bigger drawings on A4 sheets suitable reduction scale to be used or multiple sheets may be used for detailed and assembly drawings.

First the border and the title block to be drawn only for the first sheet of the chapter. Eg. for conical sections only first sheet will have the title block whereas the rest of the sheets of that chapter will have only borders.

Serial number of sheet and total no. of sheets to be mentioned on each sheet.

The completed sheet to be punched and filled in a box file/ suitable files and preserved by the trainees carefully after the approval of instructor, VP and Principal of the Institute.

The file may be referred by the authority before granting the internal marks at the end of the Year.

CONTENTS

Exercise No.	Topic of the Exercise	Page No.
	Introduction to Engineering Drawing and Drawing Instruments	
1.1.01	Introduction to engineering drawing and drawing instruments	1
1.1.02	Conventions	4
1.1.03	Sizes and layout of drawing sheets	5
1.1.04	Title block, its position and content	7
1.1.05	Drawing instruments	11
	Free hand drawing	
1.2.06	Free hand drawing of - Geometrical figures and blocks with dimension	16
1.2.07	Free hand drawing of - Transferring measurement from the given object to the free hand sketches	20
1.2.08	Free hand drawing of hand tools	25
	Drawing of Geometrical Figures	
1.3.09	Drawing of geometrical figures - Angle & triangle	32
1.3.10	Drawing of geometrical figures - Circle	35
1.3.11	Drawing of geometrical figures - Square, rectangle and parallelogram	37
1.3.12	Lettering and numbering - Single stroke	39
	Symbolic Representation	
1.4.13	Symbolic representation - Different electronic symbols used in the related trades	43
	Reading of Electronic Circuit Diagram	
1.5.14	Reading of electronic circuit diagram	46
	Reading of Electronic Layout drawing	
1.6.15	Reading of electronic layout drawing	54

LEARNING / ASSESSABLE OUTCOME

On completion of this book you shall be able to

- **Read and apply engineering drawing for different application in the field of work.**

SYLLABUS

1st Year

Group 20 - Revised syllabus July 2022
2 Year Engineering trades under CTS

Duration: 1 Year

CTS Trades Covered: Instrument Mechanic, Tech. Medical Electronics, Technician Mechatronics, Technician Power Electronics System, Electronics Mechanic, Mechanic Consumer Electronics Appliances, Tech. Electronic System Design & Repair

S.no.	Syllabus	Time in Hrs
1	Introduction to Engineering Drawing and Drawing Instruments – <ul style="list-style-type: none">• Conventions• Sizes and layout of drawing sheets• Title Block, its position and content• Drawing Instruments	2
2	Free hand drawing of - <ul style="list-style-type: none">• Geometrical figures and blocks with dimension• Transferring measurement from the given object to the free hand sketches.• Free hand drawing of hand tools.	6
3	Drawing of Geometrical figures: <ul style="list-style-type: none">• Angle, Triangle, Circle, Rectangle, Square, Parallelogram.• Lettering & Numbering - Single Stroke.	4
4	Symbolic representation - <ul style="list-style-type: none">• Different Electronic symbols used in the related trades.	4
5	Reading of Electronic Circuit Diagram	14
6	Reading of Electronic Layout drawing	10
	Total	40

Introduction to engineering drawing and drawing instruments

Communication

There are many different ways of communicating ideas, information, instructions, requests, etc. They can be transmitted by signs or gestures, by word of mouth, in writing, or graphically. In an industrial context the graphical method is commonly used with communication is achieved by means of engineering drawings.

If oral and written communication only were used when dealing with technical matters, misunderstandings could arise, particularly in relation to shape and size. The lack of a universal spoken language makes communication and understanding even more difficult because of the necessity to translate both words and meaning from one language to another.

However, the universally accepted methods used in graphical communication through engineering drawings eliminate many of these difficulties and make it possible for a drawing prepared by a British designer to be correctly interpreted or "read" by, for example, his German, French or Dutch counterparts.

Equally important, the components shown on the drawings could be made by suitably skilled craftsmen of any nationality provided they can "read" an engineering drawing.

Conventionally prepared engineering drawings provide the main means of communication between the "ideas" men (the designers and draughtsman) and the craftsmen (machinists, fitters, assemblers, etc.). For the communication to be effective, everyone concerned must interpret the drawing in the same way. Only then will the finished product be exactly as the designer envisages it.

To ensure uniformity of interpretation, the British Standards Institution has prepared a booklet entitled BS 308:1972, Engineering Drawing Practice. Now in three parts, this publication recommends the methods which should be adopted for the preparation of drawing used in the engineering industry.

The standards and conventions in most common use and hence those required for a basic understanding of engineering drawing are illustrated and explained in this book.

Language

1 It is the media of communication (Fig 1)

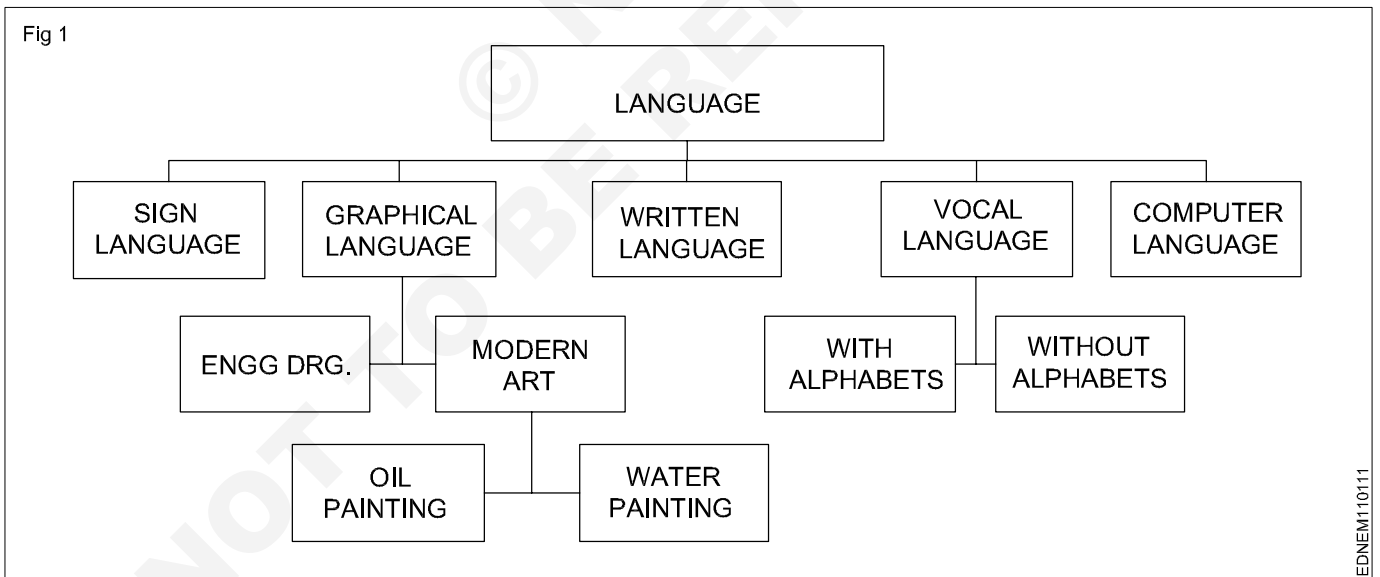

Conclusion

Effective communication is possible when graphical language is supported by written language/vocal language and vice versa.

Engineering drawing is a language that uses both graphical language and written language for effective communication.

Engineering drawing is a graphical language that also uses written language for effective communication.

The importance of Engineering Drawing

The economic success of any country is mainly dependent on its industrial development. Due to globalization, any industry in our country is expected to be of a global market standard. For the above-mentioned reasons, our Indian products require very high quality for their size, dimension, fit, tolerance, and finish etc.

To produce the best standard product, all the technical personnel (Engineers to Craftsman) in an industry must have a sound knowledge of engineering drawing because engineering drawing is the language of engineers. Engineering drawing is a universal language. Different types of lines make up their alphabets. Technical personnel in any industry, including craftsman, are expected to communicate anything concerning a part or a component by means of drawings involving lines, symbols, conventions, abbreviations etc.

With our spoken languages, it is impossible to express the details of a job or a product. Engineering drawing knowledge and practise are a must for designing or producing a component or part. Even a small mistake in the drawing may reflect very badly on the product. Therefore, reading and doing engineering drawings are very essential for craftsmen and engineers.

A drawing is a graphical representation of an object, or part of it, and is the result of creative thought by an engineer or technician. When one person sketches a rough map in giving direction to another, this is graphic communication. Graphic communication involves using visual materials to relate ideas drawings, photographs, slides, transparencies, and sketches are all forms of graphic communication. Any medium that uses a graphic image to aid in conveying a message, instructions, or an idea is involved in graphic communication.

One of the most widely used forms of graphic communication is the drawing. Technically, it can be defined as **"a graphic representation of an idea, a concept or an entity which actually or potentially exists in life"**

Drawing is one of the oldest forms of communicating, dating back even farther than verbal communication. The drawing itself is a method of communicating necessary information about an abstract, such as an idea or concept or a graphic representation of some real entity, such as a machine part, house or tools. There are two basic types of drawings: Artistic and Technical drawings.

Technical drawings

Technical drawings allows efficient communication among engineers and can be kept as a record of the planning process. Since a picture is worth a thousand words, a technical drawing is a much more effective tool for engineers than a written plan.

The technical drawing, on the other hand is not subtle, or abstract. It does not require an understanding of its creator, only on understanding of technical drawings. A technical drawing is a means of clearly and concisely communicating all of the information necessary to transform an idea or a concept in to reality. Therefore, a technical drawing often contains more than just a graphic representation of its subject. It also contains dimensions, notes and specifications.

Fields of use

Technical drawing is the preferred method of drafting in all engineering fields, including, but not limited to, civil engineering, electrical engineering, mechanical engineering and architecture.

Purpose of studying engineering drawing

- 1 To develop the ability to produce simple engineering drawing and sketches based on current practice
- 2 To develop the skills to read manufacturing and construction drawings used in industry.
- 3 To develop a working knowledge of the layout of plant and equipment.
- 4 To develop skills in abstracting information from calculation sheets and schematic diagrams to produce working drawings for manufacturers, installers and fabricators.

Main types of Engineering drawing

Regardless of branch of engineering the engineering drawing is used. However based on the major engineering branches, engineering drawing can be classified as follows: (Fig 2)

Mechanical Engineering drawings

Some examples of mechanical engineering drawings are part and assembly drawings, riveted joints, welded joints, fabrication drawings, pneumatics and hydraulics drawings, pipeline diagrams, keys coupling drawings etc. (Fig 3&4)

Electrical Engineering drawing

Wiring diagrams of home and industries, circuit diagrams, electrical installation drawings etc.

Example

The voltage supply to a filament lamp is 10.8V. The voltage should be 12V. (Fig 5)

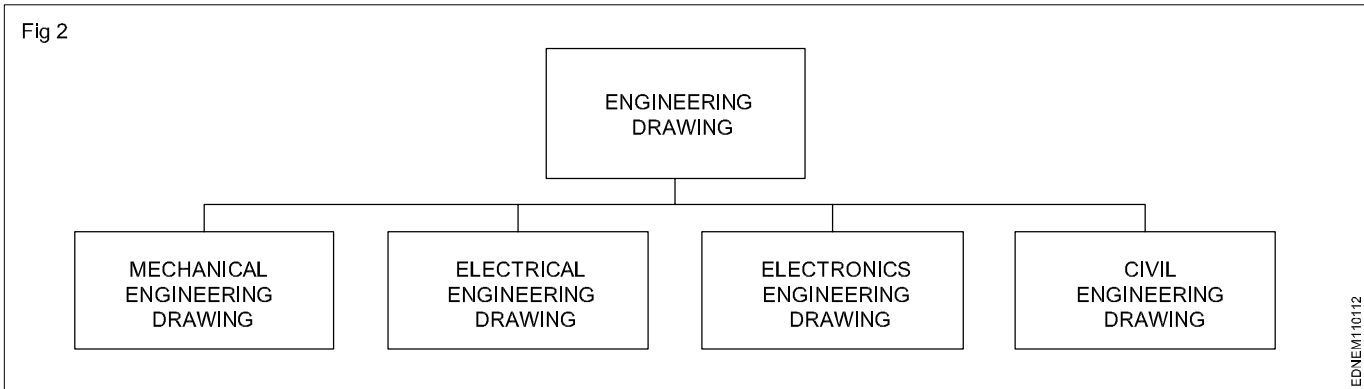

Mechanical Engineering Drawings (Fig 3&4)

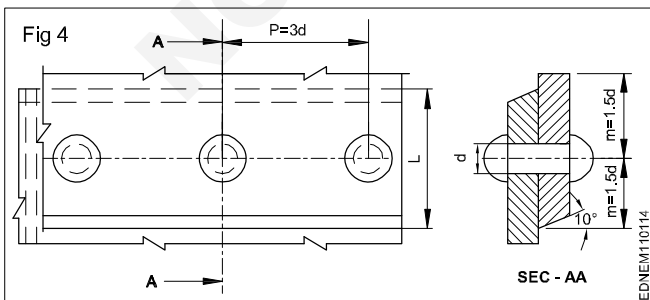
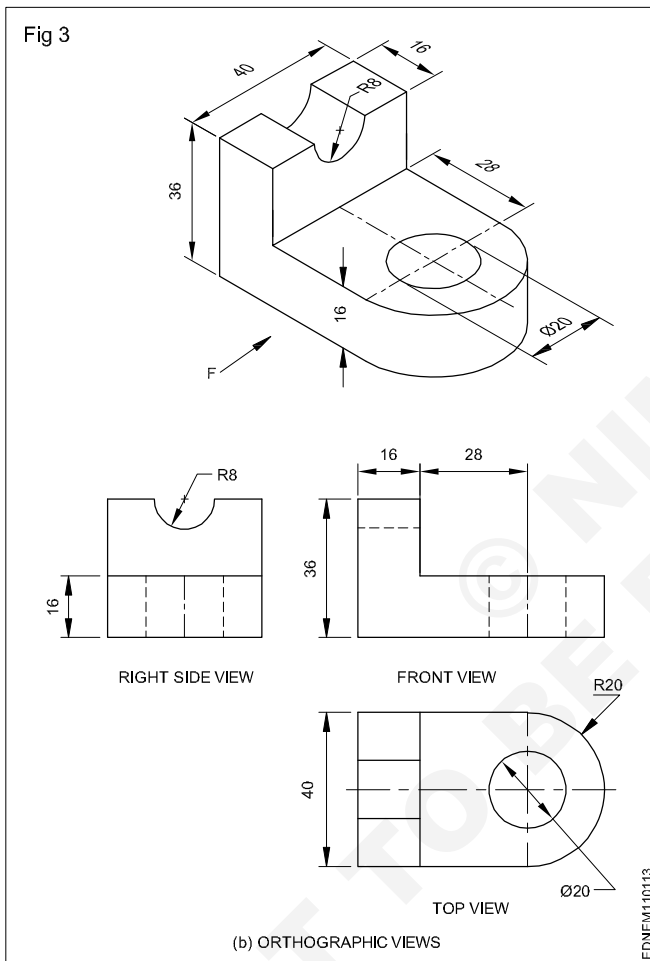

Electrical Engineering Drawing (Fig 5)

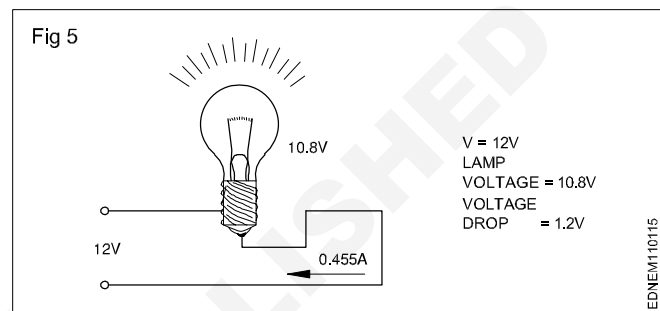

Electronics Engineering Drawing

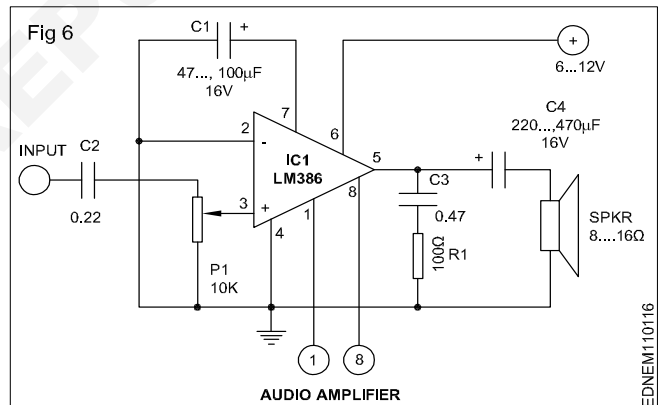

Audio amplifier (Fig 6)

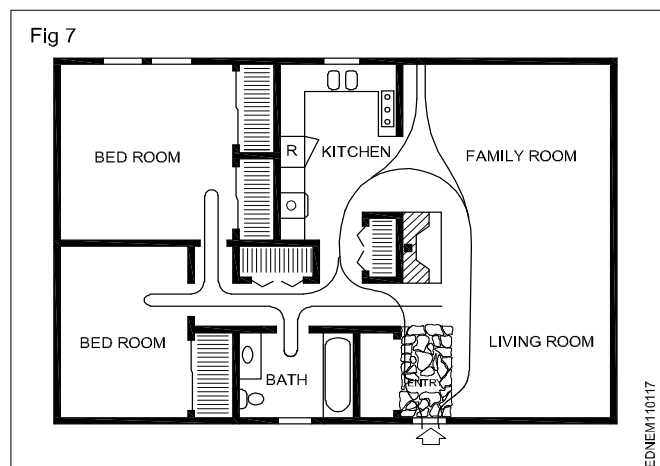

Civil Engineering Drawing (Fig 7)

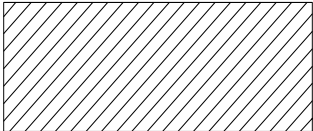
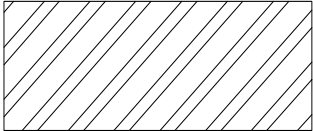
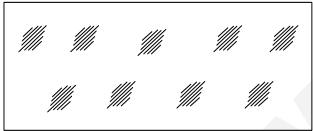
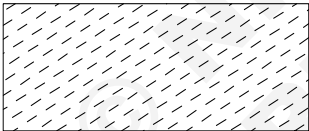
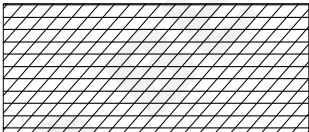
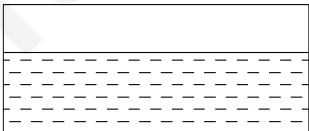

Conventions

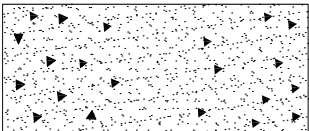
TYPE	CONVENTION	MATERIALS
Metals		Steel, Cast Iron, Copper and its Alloys, Aluminium and its alloy, etc
		Lead, Zinc, Tin, White-metal, etc.
Glass		Glass
Packing and Insulating materials		Porcelain, Stoneware, Marble, Slate etc
		Asbestos, Fibre, Felt, Synthetic resin products, Paper, Cork, Linoleum, Rubber, Leather, Wax, insulating & Filling Materials etc
Liquid		Water, Oil, Petrol, Kerosene etc
Wood		Wood, Plywood etc
Concrete		Concrete

Sizes and layout of drawing sheets

Size of drawing sheets (in mm): While being worked on or handled, the sheets are prone to tear along the edges. So slightly larger(untrimmed) sheets are preferred. They are trimmed afterwards. IS:10811:1983 lays down such as designation of preferred trimmed and untrimmed sizes.

Designation of sheets: The drawing sheets are designated by symbols such as A0, A1, A2, A3, A4 and A5. A0 being the largest. Table 1 below gives the length and breadth of the above sizes of sheets. (Trimmed and untrimmed)

The relationship between two sides is same as that between a side of a square and its diagonal.

TABLE 1

Designation	Trimmed size	Untrimmed size
A0	841 x 1189	880 x 1230
A1	594 x 841	625 x 880
A2	420 x 594	450 x 625
A3	297 x 420	330 x 450
A4	210 x 297	240 x 330
A5	148 x 210	165 x 240

Special elongated series increasing its widths, double, treble etc. are denoted as follows A3 x 3, A3 x 4, A4 x 3, A4 x 4, A4 x 5. Please refer Table 2

TABLE 2

Special elongated series

Designation	Size
A3 x 3	420 x 891
A3 x 4	420 x 1189
A4 x 3	297 x 630
A4 x 4	297 x 841
A4 x 5	297 x 1051

Fig 1 & 2 shows how the sheet sizes are formed by halving/doubling and similarity of format.

White drawing papers that do not turn yellow on exposure to air are used for finished drawings, maps, charts and drawings for photographic reproductions.

For pencil layouts and working drawings, cream-coloured papers are best suited.

Quality drawing paper: The drawing papers should have sufficient teeth or grain to take the pencil lines and withstand repeated erasing.

To get uniform lines, backing paper is to be placed on the drawing board before fixing drawing/tracing paper,. Before starting the drawing, the layout should be drawn. (Ref: IS:10711)

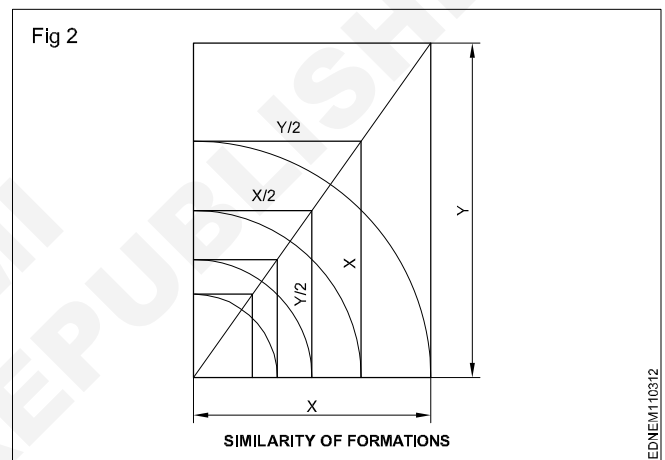
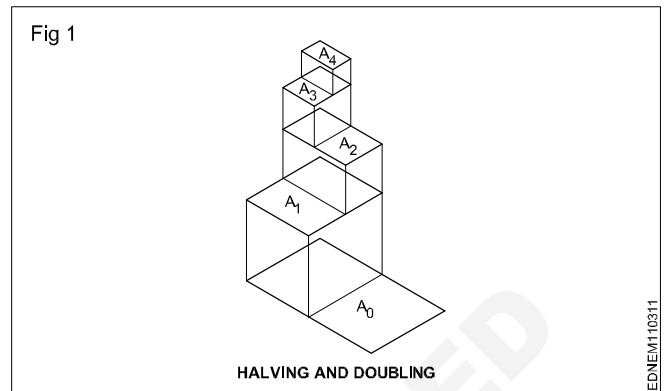

The following is the method of folding printed drawing sheets as recommended by BIS. (Fig 3)

Method of folding of printed drawing sheets as per BIS SP: 46-2003

When drawings sheets are in more numbers, they have to be folded and kept in order to save the trace required for preserving them (Fig 4).

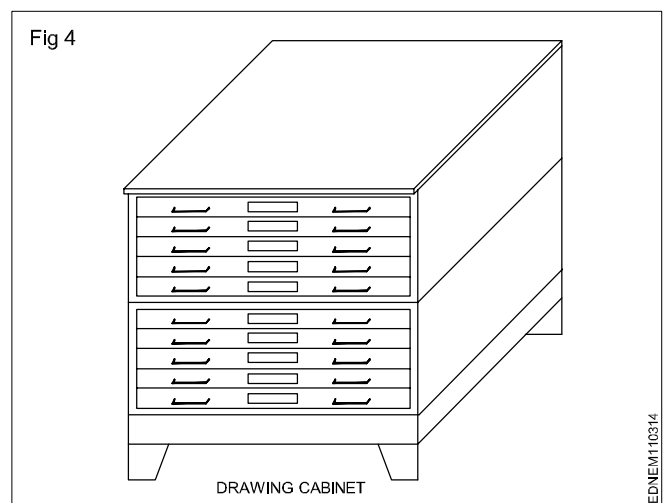

EDNEM110311

EDNEM110312

EDNEM110314

Method of folding printed drawing sheets (Fig 3)

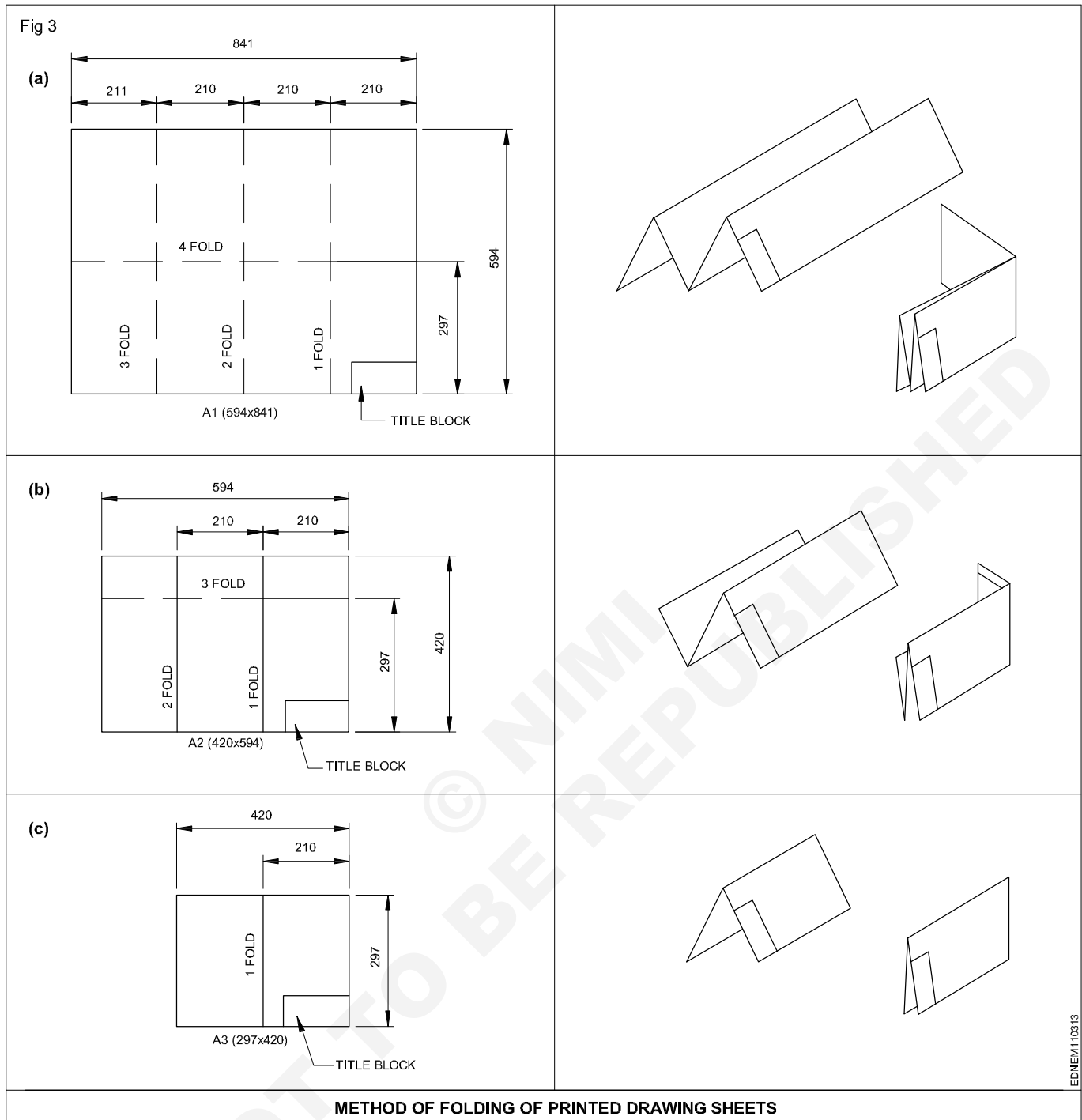

Title block, its position and content

Layout of drawing sheet

As a standard practice, sufficient margins are to be provided on all sides of the drawing sheet. The drawing sheet should have drawing space and title space. A typical layout of a drawing sheet is shown in the (Fig 1 & 2).

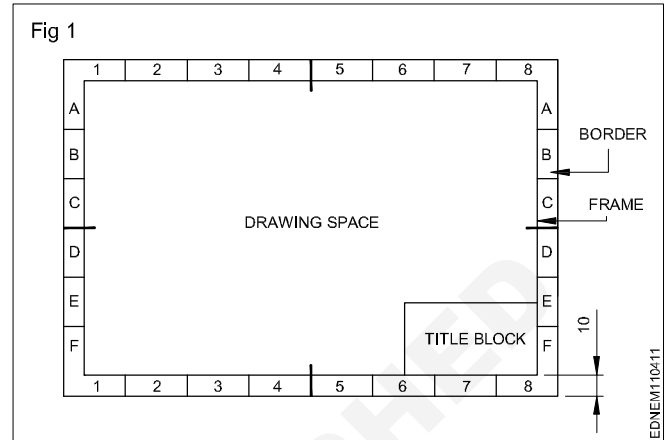

Title Block - 1

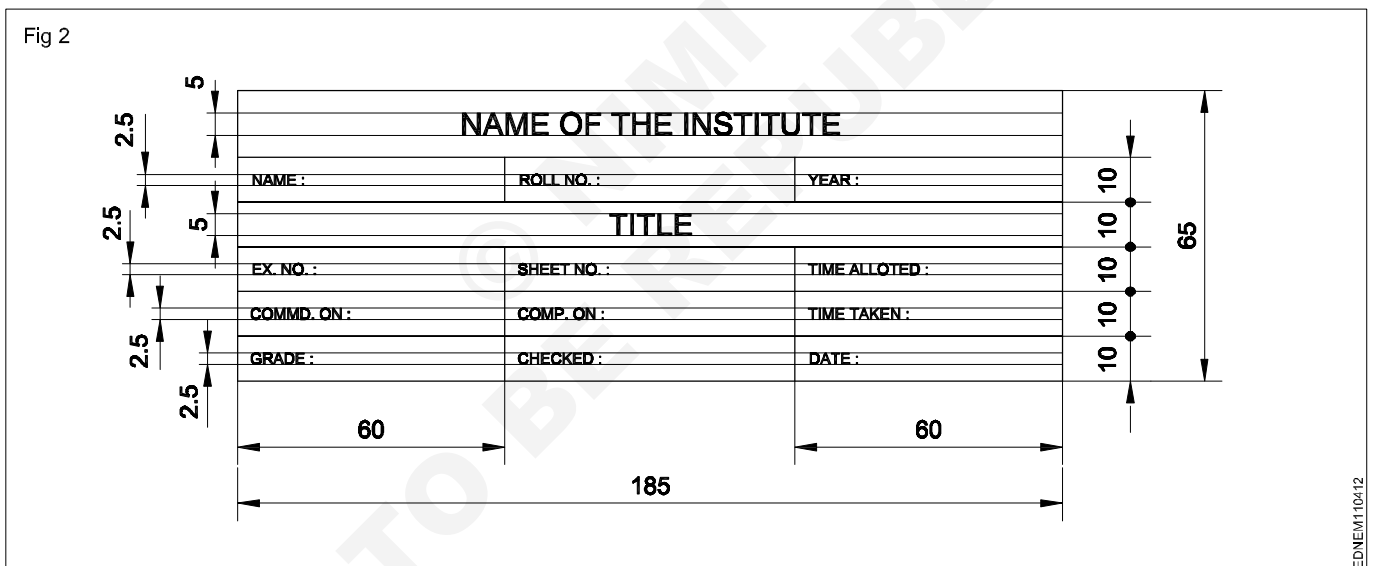

Title Block - 2

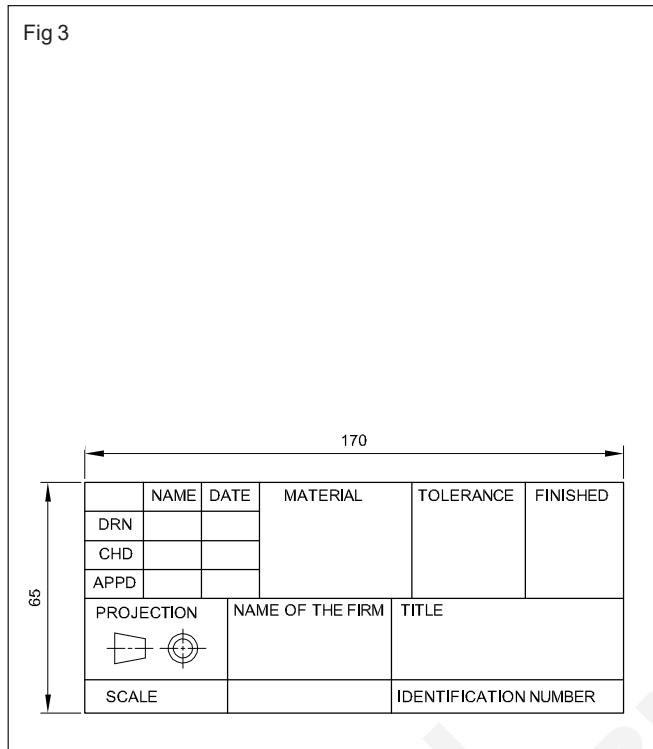

Title Block - 3

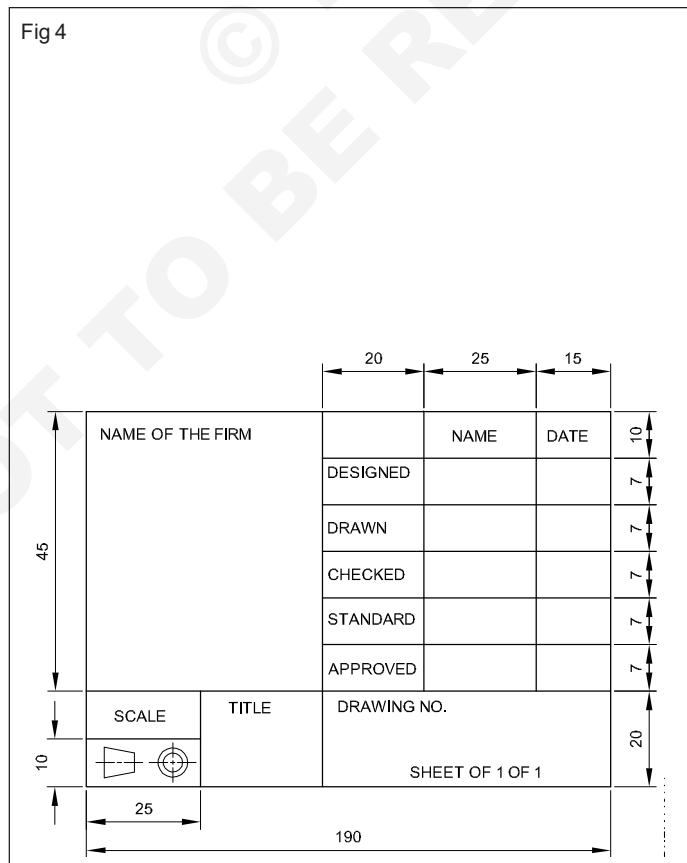

Title Block - Position and content - 1

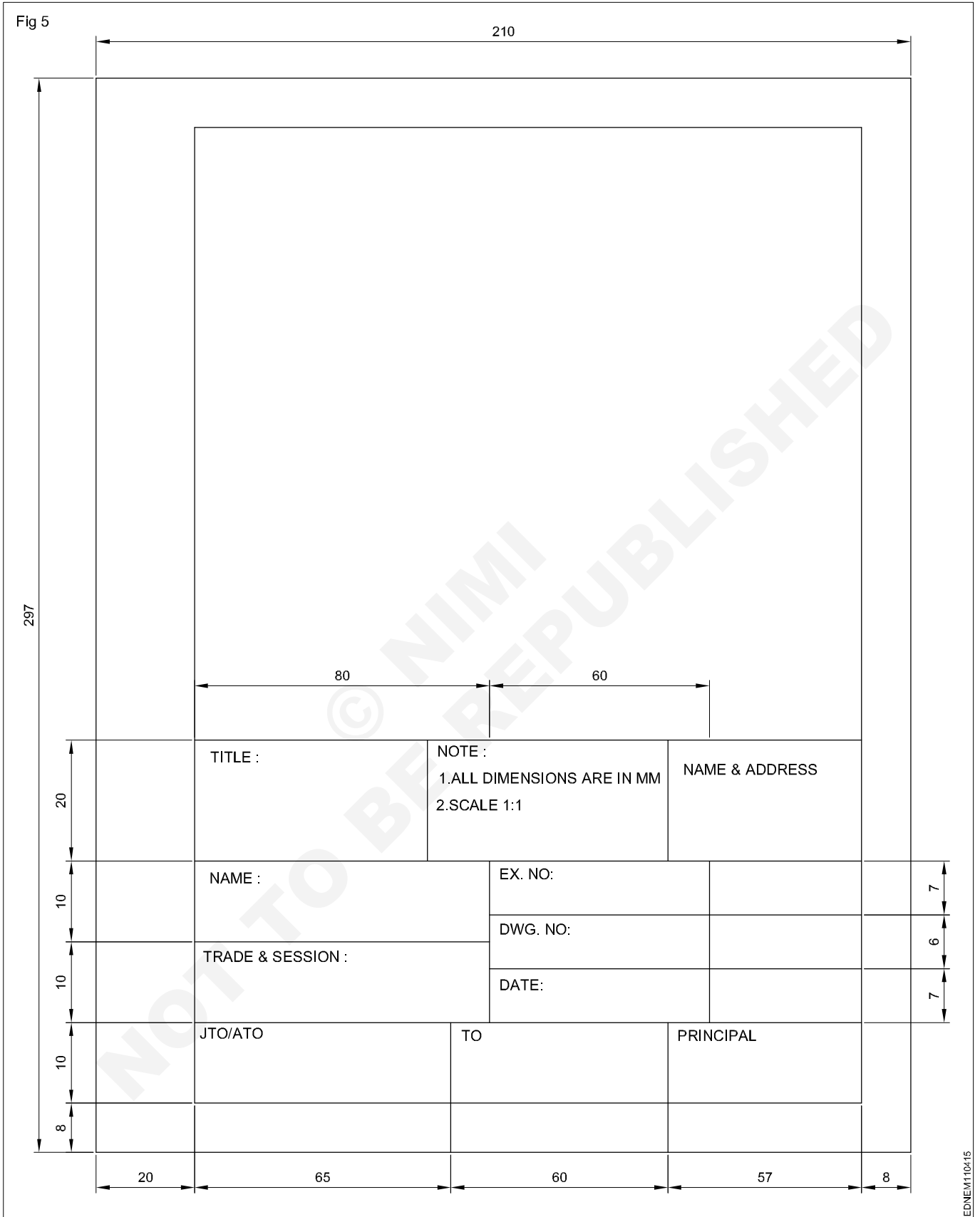

Title Block - Position and content - 2

Fig 6

DO NOT SCALE

REVISION			
SL.N	DESCRIPTION	DATE	APPX
A	M12 WAS $\frac{1}{2}$ WHIT.	14.12.18	A.W.D

4			
3			
2			
1	A7325	VALVE BODY	1
TEH	DRG OR PART NO.	DESCRIPTION	QTY.

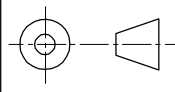
UNLES OTHERWISE STATED ALL DIMENSIONS IN MILLIMETRES. TOLERANCES LINEAR: ANGULAR:		DRN 1:1:78 JKL	(NAME OD THE FIRM)
		CKD 2:1:78 MLN	
		APPD 5:1:78 AWB	(TITLE OF DRW.)
		ISSUED 4:2:78 PFP	
DRAFTING STANDARD AS 1100	FINISH AS MACHINED	SIZE A3	DRG NO A24641
		SCALE 1:2	SHEET 1 OF 1

EDNEW110416

Item Reference on Drawing Sheet

05	TIGHTENING PIN	01	MILD STEEL	
04	WORK PIECE	01	ANY MATL.	
03	SCREW ROD	01	STD.	
02	"U" CLAMP	01	CAST IRON	
01	"V" BLOCK	01	CAST IRON	
SL.NO	DESCRIPTION OF ITEM	QTY/ASSY	MATERIAL	REMARKS
BILL OF MATERIALS				

The drawing sheet on which the drawings are to be prepared should be prepared first by following the procedure given below:

- 1 Take the A4/A3 drawing sheet.
- 2 Mark the borders and draw the title block as mentioned.
- 3 Follow the same procedure for the A3 drawing sheet where the title block is to be drawn right side bottom corner and the border dimensions remain the same.
- 4 Title block to be drawn whenever the title of the drawing changes. Eg. for the geometrical construction chapter the title block may be drawn in the first sheet only whereas on the remaining sheets borders are to be drawn before they are used for preparing drawings.

Drawing instruments

The following are the commonly used equipment in a drawing office.

Drawing board (Fig 1): Drawing board is one of the main item of equipment for Draughtsman. It is used for supporting the drawing paper/tracing paper for making drawings. It is made of well seasoned wood strips of about 25 mm thick or masonite, free from knots and warping. It should be softer enough to allow insertion and removal of drawing pins. Two battens are fastened to the board by screws, in slotted joints. They prevent warping and at the same time permit expansion and contraction of the strips due to the change of moisture in the atmosphere.

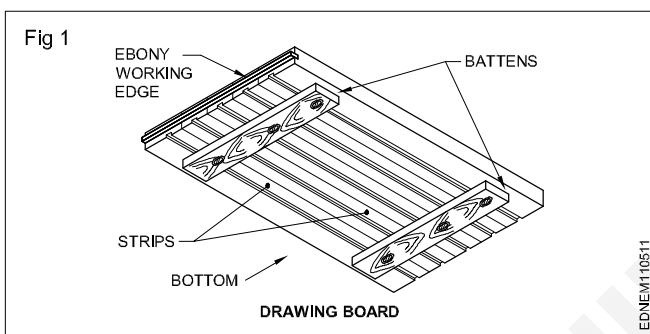

One of the shorter edges of the drawing board is provided with an "ebony edge" (hardwood) fitted perfectly straight.

Standard drawing boards are designated as follows as per IS:1444-1989.

Sl. No.	Designation	Size (mm)
1	D0	1500 x 1000 x 25
2	D1	1000 x 700 x 25
3	D2	700 x 500 x 15
4	D3	500 x 350 x 15

The working edge (ebony) must be straight.

Nowadays drawing boards are available with laminated surfaces. The flatness can be checked by placing a straight edge on its surface. If no light passes between them, the surface is perfectly flat.

'T' Square: It is of 'T' shape, made of well-seasoned wood. It has two parts., head / stock and blade. One of the edges of the blade is the working edge. The blade is screwed to this head such that the working edge is at a right angle to the head. (Fig 2a)

The standard 'T' square is designated as follows with dimensions shown in mm; as per IS:1360-1989.

Sl. No.	Designation	Blade length
1	T0	1500
2	T1	1000
3	T2	700
4	T3	500

The 'T' square is used with its head against the ebony edge of the drawing board to draw horizontal lines, and parallel lines and to guide/hold the set squares, stencils etc.

Fig 2b shows how the 'T' square is used.

'T' square should never be used as a hammer or as a guide for trimming papers.

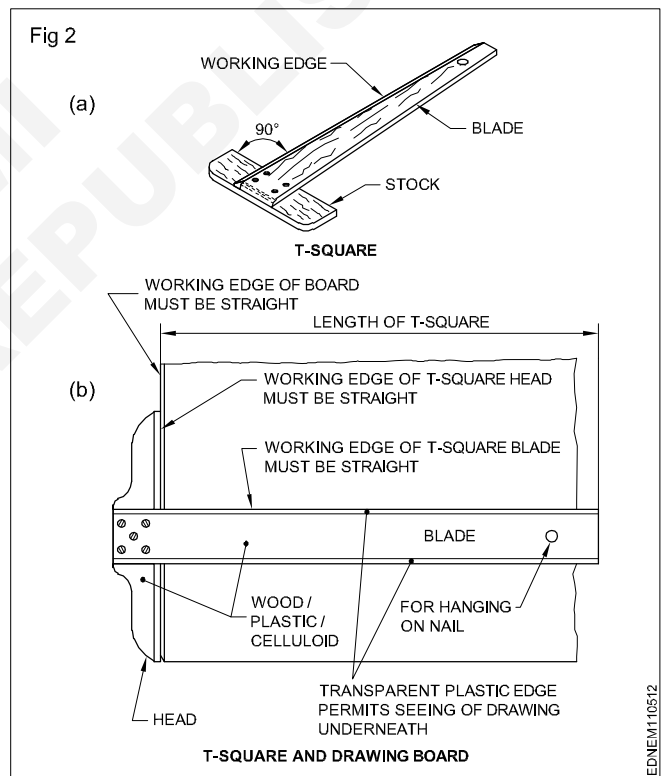

Drafting in the machine (Fig 3): It serves the functions of a Tee square, set square, protractor and scale. They come in different sizes and have a pattern called the 'Pantograph' type. It is fitted on the top left side, edge of the drafting board, mounted on an adjustable frame or table. It requires a large area of working place. The angle of the drafting board can be adjusted by the pedal operating system. There are two counterweights to balance the angular position of the board and the drafting head. It is more suitable for the production drawing office.

Fig 3

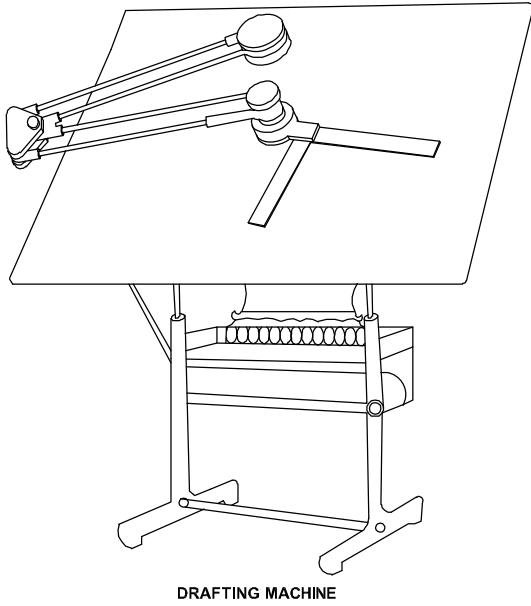

DRAFTING MACHINE

EDNEM110513

On the other end, a protractor head H with swivelling and locking arrangement is fitted with two scales at right angles.

The protractor head has a spring-loaded clutch relieving handle, which rotates and locks at 15° intervals automatically. For setting any angle other than multiples of 15°, the clutch spring is released and by rotating the centre knob, the zero line is set to the required angle and the friction clutch knob is tightened. It is capable of rotating 180°, thereby any angle can be set.

The scales are bevelled on both sides, graduates to 1:1 & 1:2. They can be reversed with the help of dovetail slide fitting.

There is a fine adjusting mechanism on the drafting head to set the scale parallel to the edge of the board. The scales also can be adjusted if there is an error in measuring 90° between them.

The mini drafter is an important device used for making drawing quickly & accurately. This instrument has the combination of T-square, set square, protractor and scales, it helps to draw the drawings at a faster rate. (Fig 4,5 & 6)

Fig 4

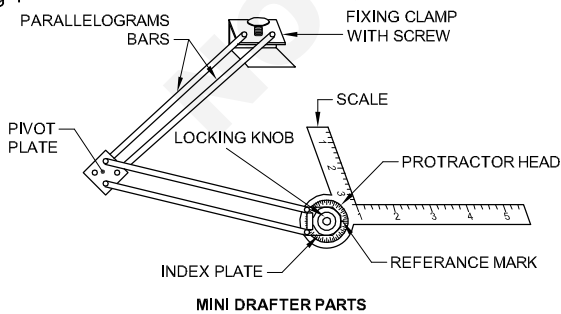

MINI DRAFTER PARTS

EDNEM110514

Fig 5

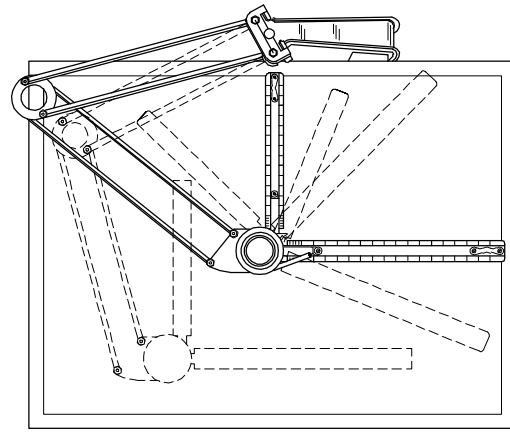

MINI DRAFTER ADJUSTMENT

EDNEM110515

Fig 6

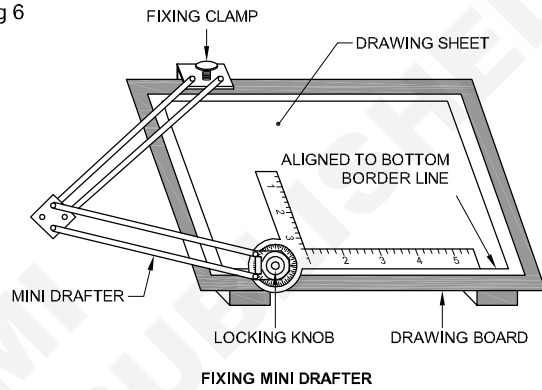

FIXING MINI DRAFTER

EDNEM110516

Erasing shield: When, on a drawing, if a part of a line or some lines among many other lines needs to be erased or modified, in a normal way erasing will damage the other nearby lines. In such a situation an erasing shield is effectively useful. It is a thin metallic sheet having small openings of different sizes and shapes. A suitable opening is aligned to the line to be erased and the line is removed by the eraser. (Fig 7)

Fig 7

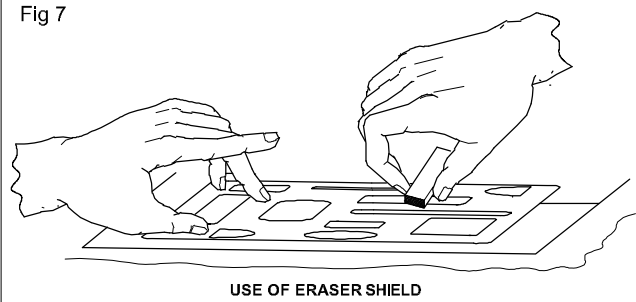

USE OF ERASER SHIELD

EDNEM110517

Set square (IS:1361-1988): Transparent celluloid /Plastic set squares are preferred and are commonly used rather than ebonite ones. They are two in number, each having one corner with 90°. The set square with 60° & 30° of 250 mm long and 45° of 200mm long is convenient for use. (Fig 8)

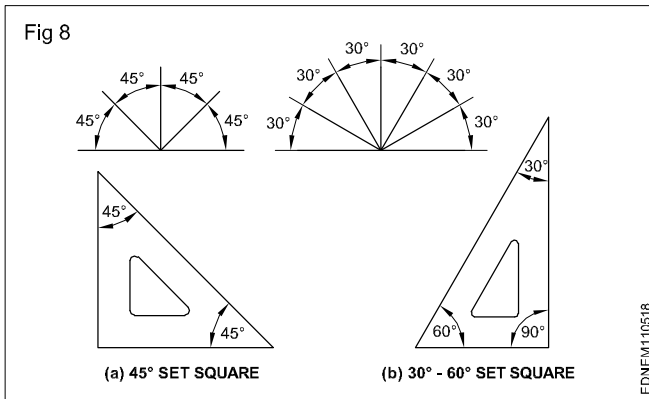

Scales: Scales are used to transfer and or measure the dimensions. They are made of wood, steel, ivory, celluloid or plastic, stainless steel scales are more durable. different types of scales used are shown in Fig 9. They are either flat, bevel-edged or triangular cross-sections. Scales of 15cm long, 2cm wide or 30cm long 3.5cm wide are in general use.

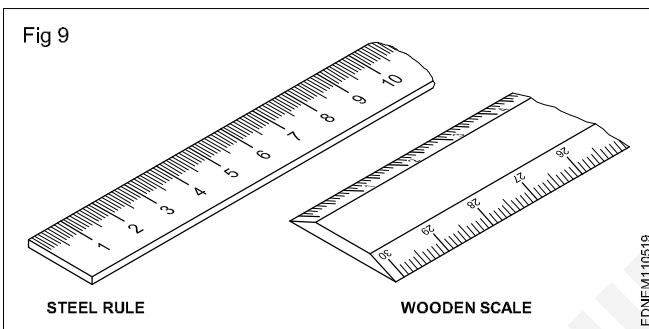

Protractor: A protractor is an instrument for measuring angles. It is semi-circular or circular and is made of a flat celluloid sheet.

The angles can be set or measured from both sides, aligning the reference line and point '0' with the corner point of the angle.

Figure 10 shows how to read or set the angle. A protractor can also be used to divide a circle or draw sectors.

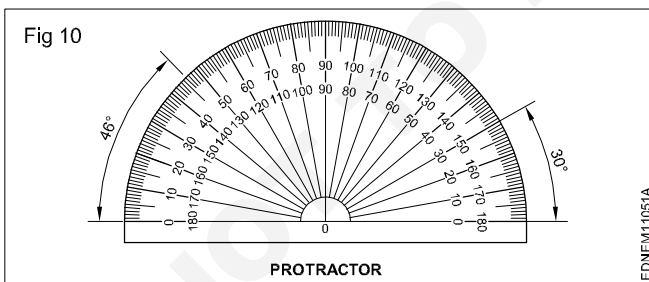

French curves (Fig 11)

These are made in many different shapes, normally come in sets of 6, 12, 16 etc. French curves are best suited to draw smooth curves/arcs (which cannot be drawn by a compass) with ease. To draw a smooth curve using a french curve first set it by trial against a part of the line to be drawn, then shift it to the next portions.

Fig 12 shows how to use the french curve and draw smooth curves. They are made of transparent celluloid (no bevel edge).

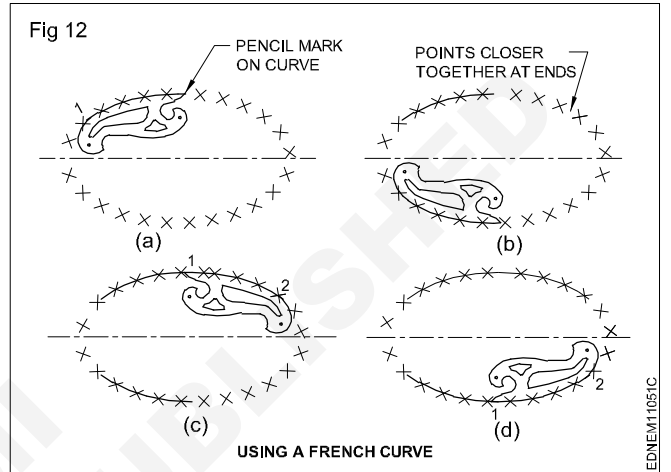
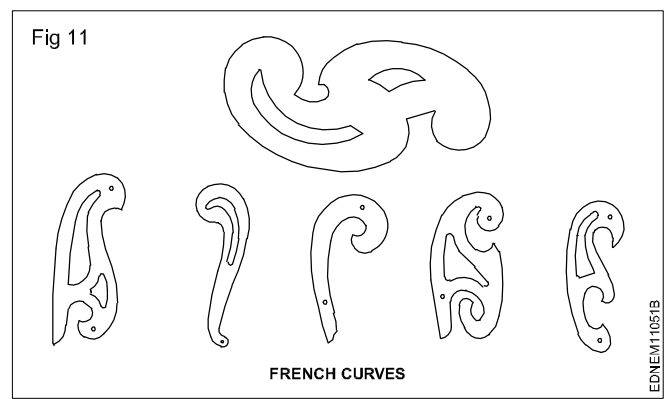

An instrument box contains the following: (Fig 13a to h)

- Large compass (with attachment facility) (a)
- Large divider (b)
- Bow compasses(pencil/ink), bow divider (c)
- Lengthening bar (d)
- Pen point for attachment (e)
- Screwdriver (f)
- Lead case (g)
- Liner (h)

Large compass (Fig 14): It has a knee joint in one leg that permits the insertion of a pen or pencil point or attaching a lengthening bar with a pen or pencil point attached to it. It is used for drawing large circles/arcs and also for taking large measurements.

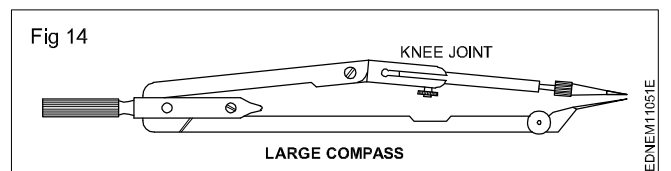

As a rule, while drawing concentric circles, small circles should be drawn first before the centre hole gets worn.

Large divider: It is used to transfer dimensions and divide lines into several equal parts. Divider with adjustable joints is preferable rather than plain legs. (Fig 15)

Fig 13

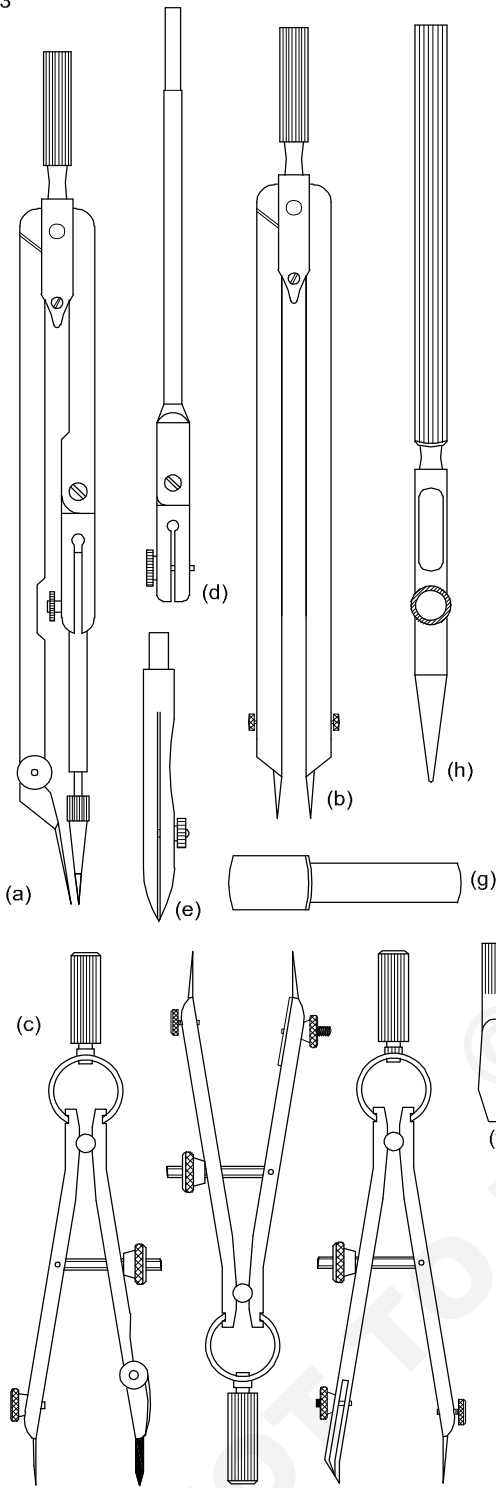

DRAWING INSTRUMENTS

EDNEM11051D

Fig 15

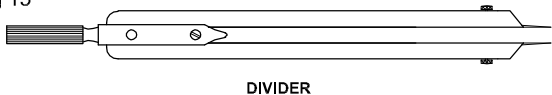

DIVIDER

EDNEM11051F

Bow instruments: Bow pencil and bow pen compass are used for drawing circles of approximately 25 mm radius. A bow divider is used for marking or dividing smaller spaces. There are two types (i) Integral legs with spring action (ii) two legs are held with a curved spring on top with a handle on it.

Fig 16 shows different types of bow instruments. Adjustments should be made with the thumb and middle finger.

Fig 16

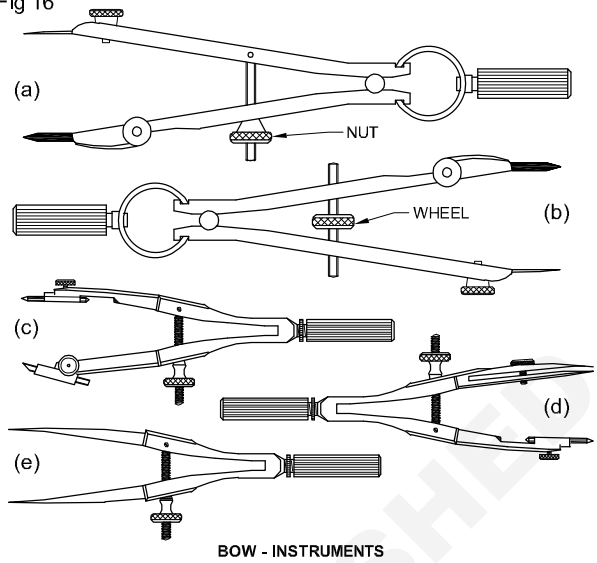

BOW - INSTRUMENTS

EDNEM11051G

Drop spring bow pencil and pen (Fig 17): Drop spring bow pencil and pen are designed for drawing multiple identical small circles. Example: rivet holes, drilled/reamed holes. The central pin is made to move freely up and down through the tube attached to the pen or pencil unit.

Fig 17

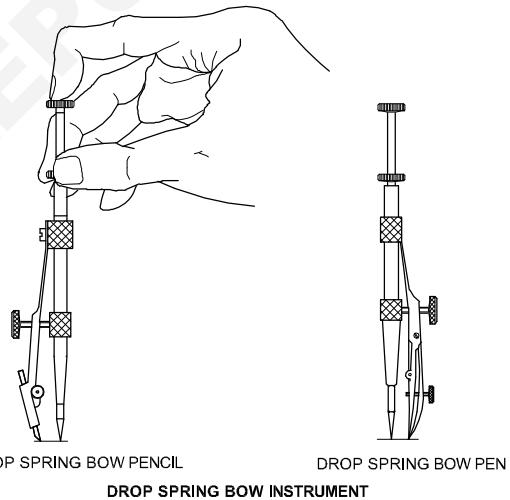

DROP SPRING BOW PENCIL

DROP SPRING BOW PEN

DROP SPRING BOW INSTRUMENT

EDNEM11051H

Inking pen or liner or ruling pen (Fig 18): It is used to ink the straight lines drawn with the instruments but never for freehand lines or lettering.

Fig 18

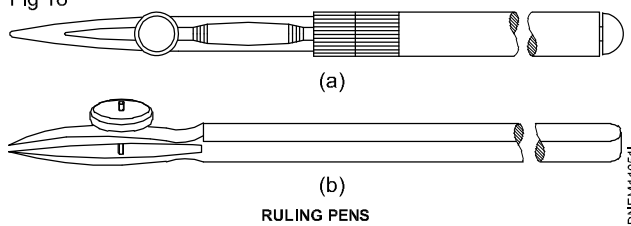

(a)

(b)

RULING PENS

EDNEM11051I

Lengthening bar (Fig 19): To draw larger circles, it is fitted to the compass. The pencil point or pen point is inserted into its end.

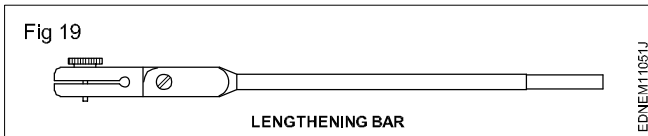

Replaceable spare pencils, pens and needle points for the compass are available in the instrument box.

Screwdriver (Fig 20): Used for adjusting the screws of the instruments.

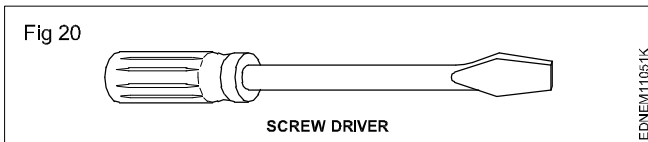

Lead case (Fig 21): Lead case is the box for holding the pencil leads.

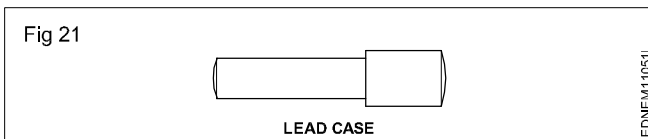

Pin, Clip, Cello tape: Drawing sheet should be fastened onto the drawing board firmly temporarily so that it does not shake during preparing the drawing. For this purpose, the pins, clips and cello tapes are used (Fig 22)

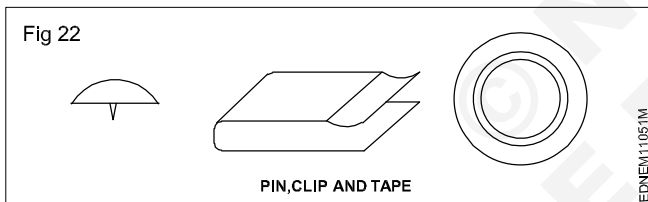

Pencils, Grade and Selection (Fig 23)

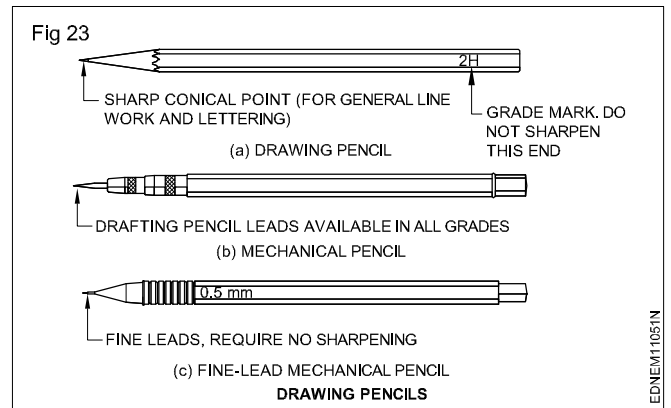

Grades of pencils: Pencils are graded according to the hardness or softness of the lead.

The hardest pencil is 9H grade and the softest pencil is 7B grade. The selection of the grade of pencils depends on the type of line work required and the paper on which it is used.

Softer lead pencils are used to produce thicker and darker line work, but they wear out quickly. Medium grades of H and 2H are used for general line work as well as for lettering.

Selection of pencils: Pencil grades vary from one brand to another brand. Select the grades of the pencil depending upon the type of line work. For construction lines, you can choose 2H or 3H, for lettering and object lines grade H pencils. In general H, HB and 2H are used.

H - medium-hard

HB - medium-soft

2H - hard

Now-a-days automatic (Mechanical) pencils or clutch pencils are available in different sizes (lead dia. 0.3, 0.5, 0.7 or 0.9). Leads can be replaced as per the required grade of hardness. They produce lines of uniform width without sharpening.

Free hand drawing of - Geometrical figures and blocks with dimension







Lines - Types and applications in drawing

Drawings are made up of different types of lines. Just a language with alphabet and grammar.

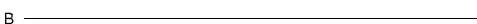
Lines of different thicknesses and features are used for specific use.

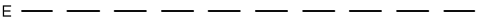
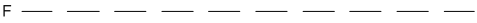
Technical drawings are drawn with different types of lines. By proper choice and application of lines, product features can be correctly defined in a drawing. Different types of lines recommended for specific applications are given in Table 1.

Table 1
Types of lines and their application

Lines	Description	General applications See figure and other relevant figure
A  0.5	Continuous thick	A1 Visible outlines A2 Visible edges
B  0.2	Continuous thin (straight)	B1 Imaginary lines of intersection B2 Dimension lines B3 projection lines or extension line B4 Leader lines B5 Hatching / Section line B6 Outlines of revolved sections in place B7 Short centre lines B8 Thread line B9 Diagonal line
C  0.2	Continuous thin free hand	C1 Limits of partial or interrupted views & sections, if the limit is not a chain thin
D  0.2	Continuous thin (Straight) with zig-zags	D1 Line (See figures)
E  0.3	Dashed thick	E1 Hidden outlines E2 Hidden edges
F  0.2	Dashed thin	F1 Hidden outlines F2 Hidden edges
G  0.2	Chain thin	G1 Centre lines G2 Lines of symmetry G3 Trajectories
H  0.3	Chain thin, thick at ends & changes of direction	H1 Cutting planes
J  0.5	Chain thick	J1 Indication of lines or surfaces to which a special requirement applies
K  0.2	Chain thin double-dashed	K1 Outlines of adjacent parts K2 Alternative and extreme positions of movable parts K3 Centroidal lines K4 Initial outlines prior to forming K5 Parts situated in front of the cutting plane

- 1 This type of line is suited for production of drawings by machines.
- 2 Although two alternatives are available, it is recommended that on any one drawing, only one type of line be used.

In the above range, for craftsmen, 0.5 is preferred. This table shows the 0.5 line range and other lines under this range.

The numbers on the right side of the lines refer to the line thickness in mm.

Geometrical figures and blocks with dimension

Freehand sketching: Apart from making drawing using instruments, often craftsmen will be required to make drawings with their free hand.

Freehand sketching is the easiest method to express the shape of a piece part or a component by an engineer or craftsman.

Freehand sketches are not usually made to scale. However, they should be as nearly to the proportions as possible.

Cube (Fig 1)

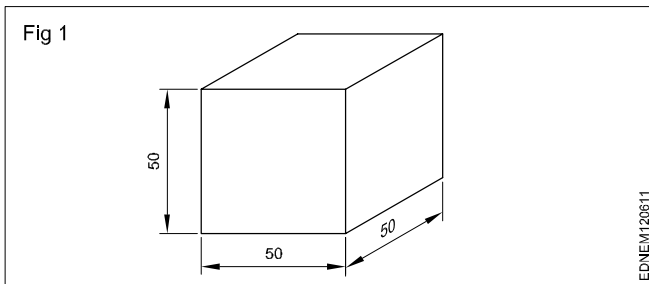

Square block (Fig 2)

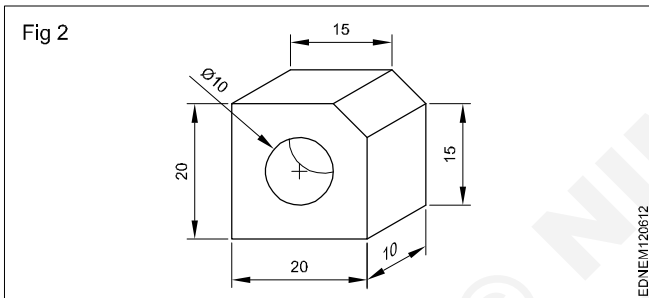

Rectangular block (Fig 3)

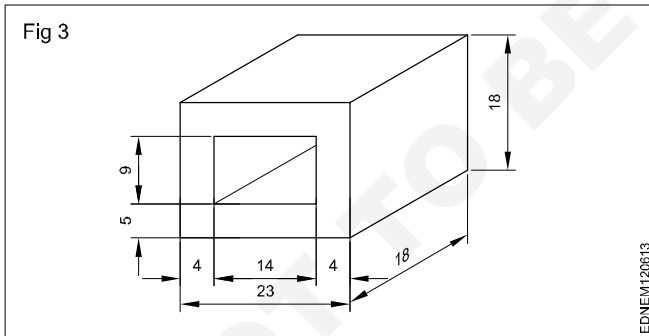

Cube block (Fig 4)

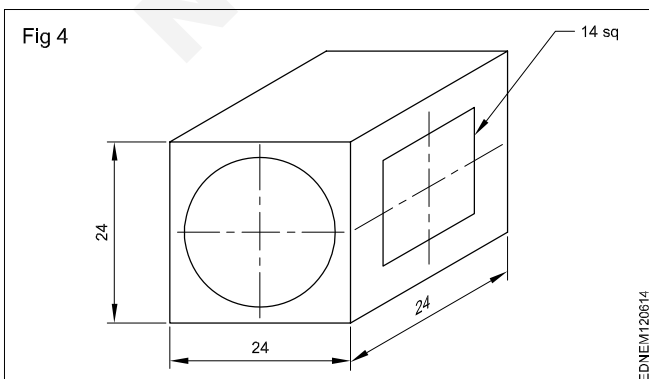

Cylinder (Fig 5)

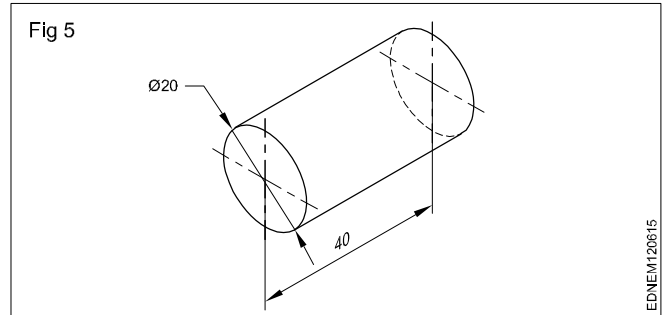

Materials for free hand sketching: A4 size sheet (preferably a pad instead of loose papers) pencils of soft grade. Example H, HB, and a good quality eraser are the only materials required. For drawing different darkness, the pencil points should be sharpened to a conical shape. Fig 6 shows some free hand sketches of different types of views.

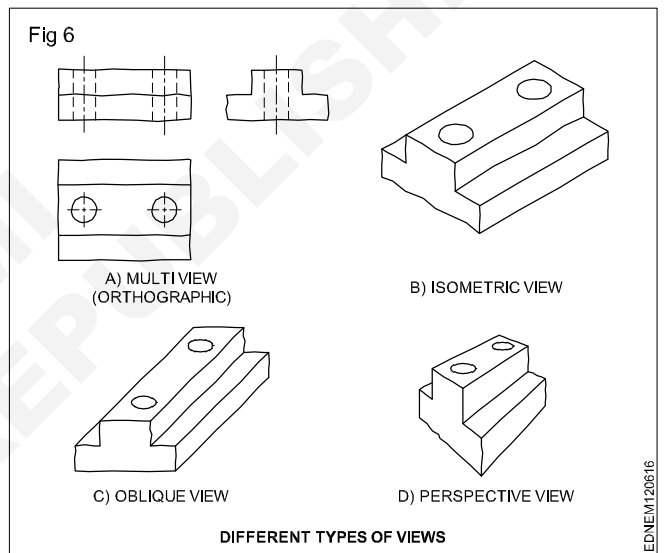

Procedure

Freehand drawing of solid figures, cubes, cuboids, cone, prism, pyramid, frustum of a cone with dimensions

Cube (Fig 1)

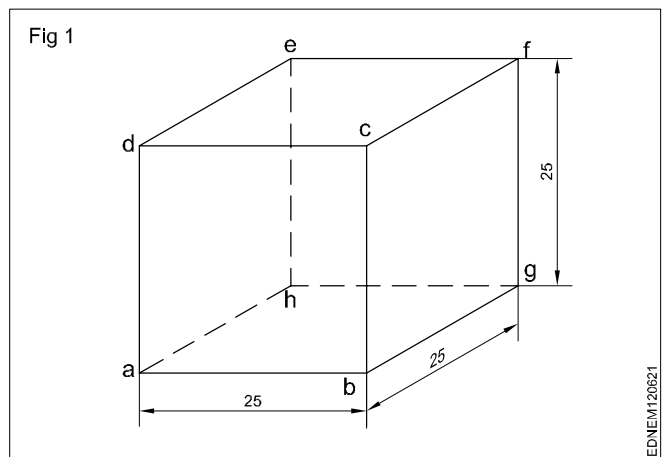

- Draw squares of a, b, c and d.
- Draw 30° from points b, c and d for the length of 25mm.
- Mark point g from b, f from c and e from d as shown in the figure.
- Joint all points.

Cuboid (Fig 2)

Draw the isometric drawing of a cuboid of base 60 mm x 40 mm and the height of 20 mm. (Fig 2)

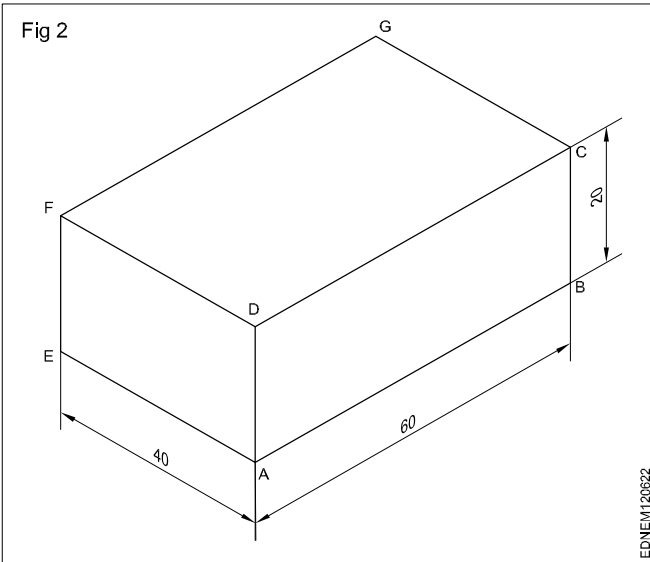

Draw the three isometric axes through the point 'A'.

- Mark AB = 60mm, AE = 40mm and AD = 20mm representing the three sides of cuboid.
- Draw two vertical lines EF and BC parallel to AD from points E and B respectively.
- Similarly, draw two more lines parallel to AB and AE to mark G's interesting point from F and C.
- Draw lines parallel to DC and FG Draw lines parallel to DF and GC.
- Join all the points.

Cylinder (Fig 3)

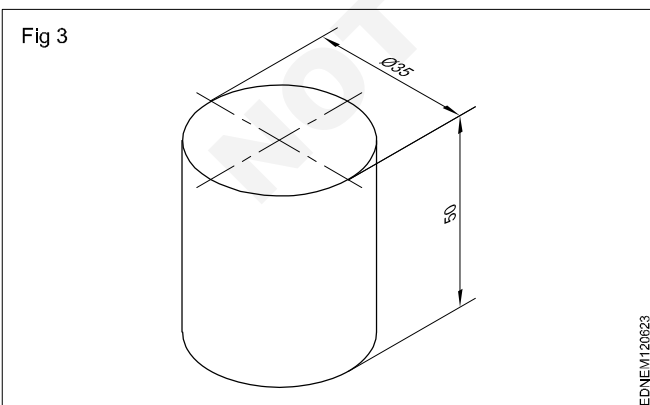

Rectangular prism (Fig 4)

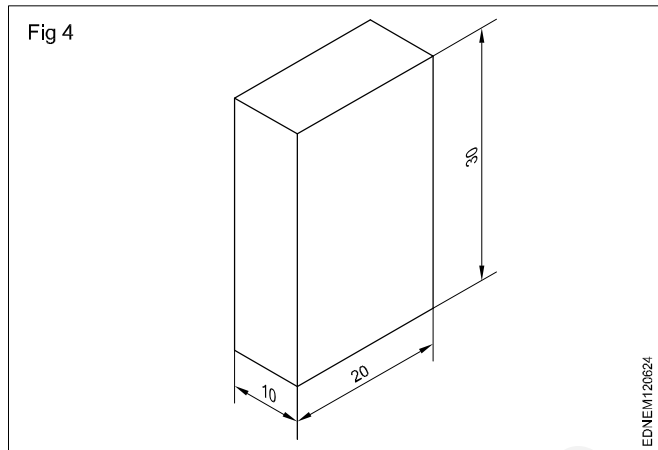

Square Prism (Fig 5)

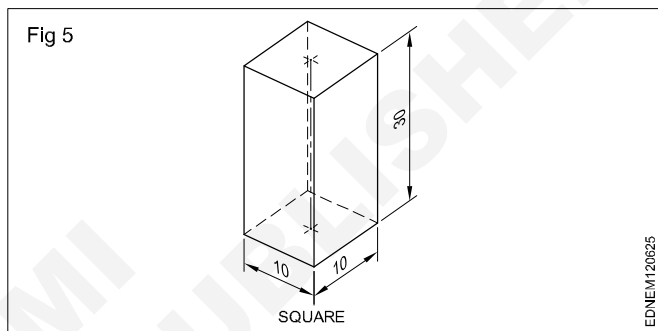

Triangular Prism (Fig 6)

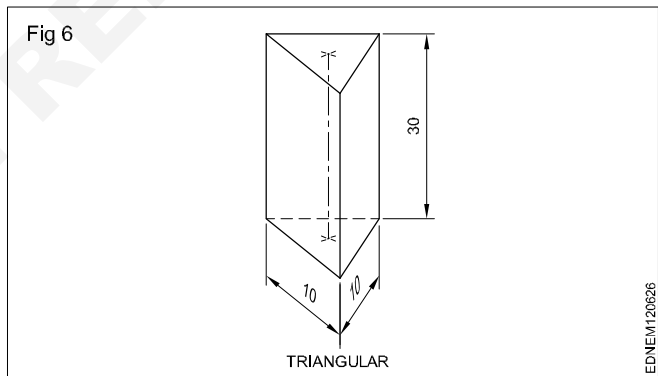

Pentagonal prism (Fig 7)

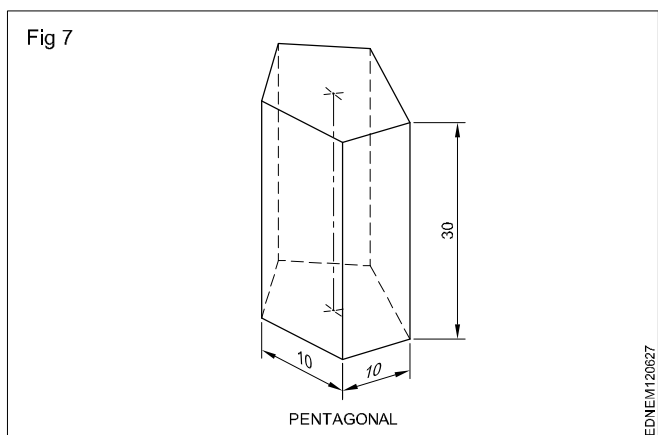

Hexagonal prism (Fig 8)

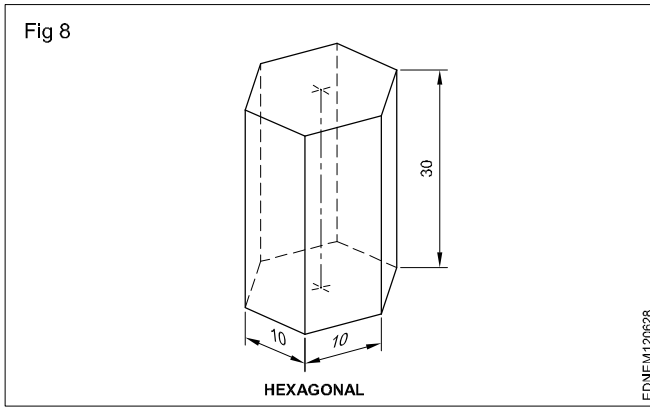

Cone: When a right-angled triangle revolves about one of its sides forming the right angle, a cone is generated. Cone forming has a circular face and a slant curved surface. (Fig 9)

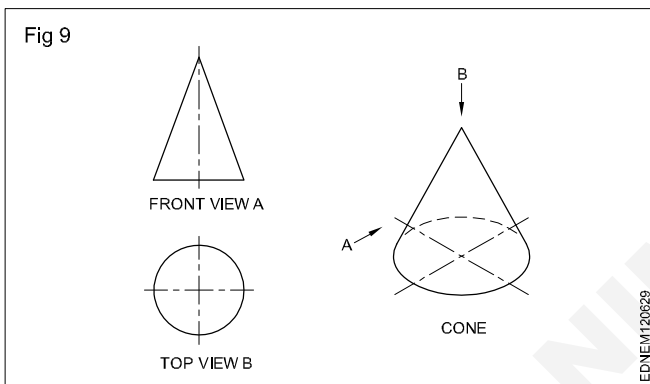

Pyramids: Pyramids are polyhedron solids having a base surface whose shape may be triangular, square or polygon and as many slant triangular faces as there are sides in the base. All the slant triangular faces join at a common point called APEX.

Similar to prisms, pyramids also are known by the shape of their base viz triangular, square, rectangular, pentagonal, hexagonal etc. The imaginary line joining the centre of the base to the apex is called the AXIS.

Fig 10 shows some pyramids and their views.

When a semi-circle revolves about its diameter a sphere is generated. A sphere has no flat surface. (Fig 11D)

Frustums: Pyramid/cone is cut parallel to the base and the top portion is removed. The remaining bottom portion is called the frustum of a pyramid/cone.

If the cutting plane is at an angle to the axis/base, the pyramids or cones are called "Truncated pyramids or cones".

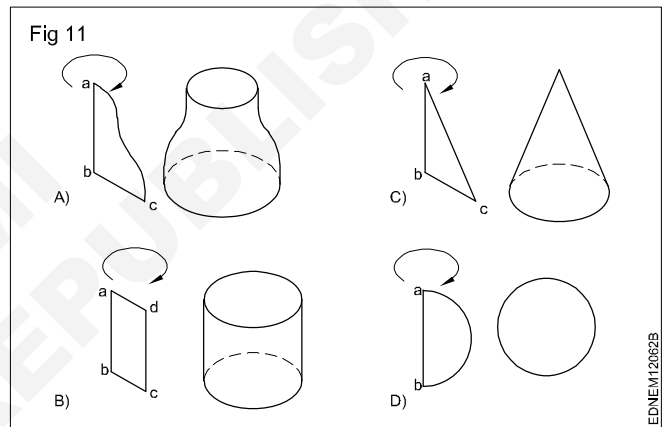
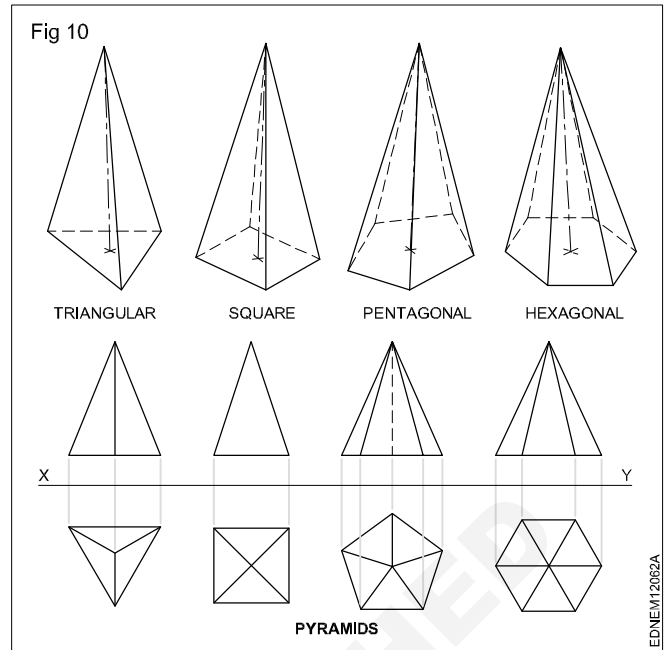
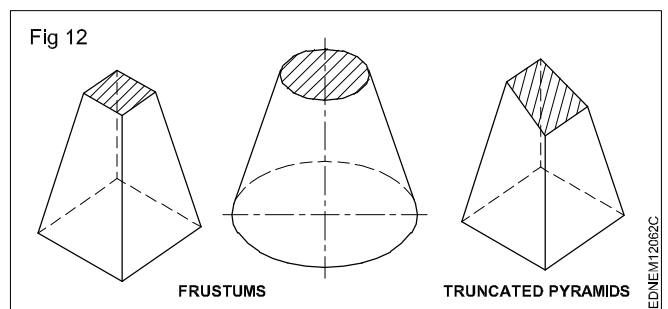

Fig 12 shows frustums and truncated pyramids.

All items we use are solids. Their shapes may confirm individual geometrical solids like prisms, cones or other combinations.



Free hand drawing of - Transferring measurement from the given object to the free hand sketches

Dimensioning - Types of arrow heads and leader line with text

Dimension line: These are thin continuous lines, terminated at ends by arrowheads, dots or oblique lines touching the extension line. (Fig 1)

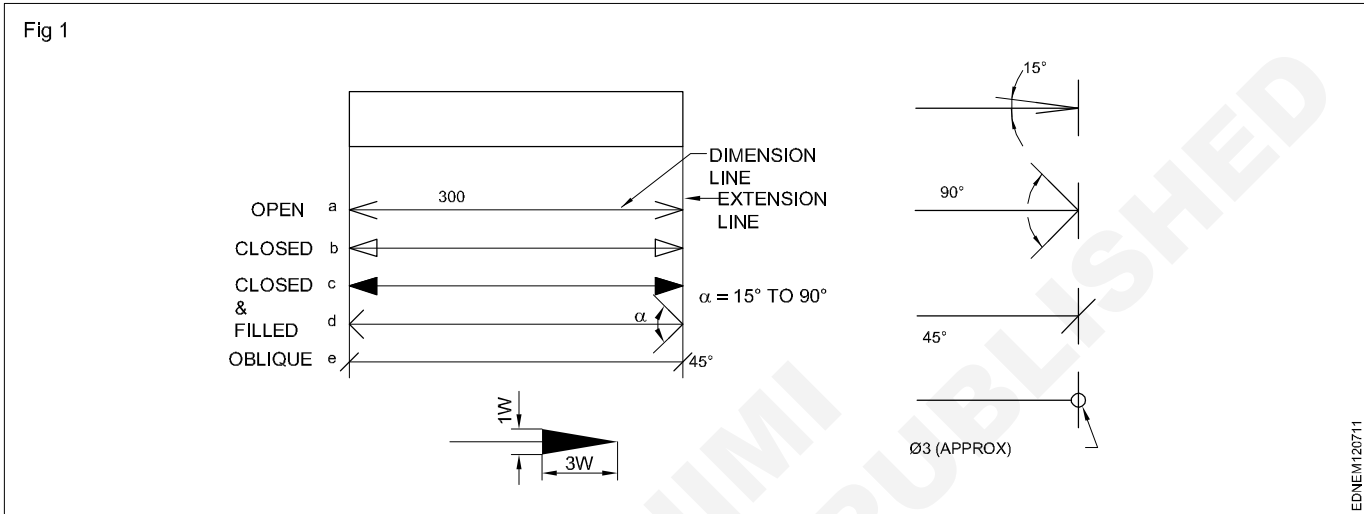

Dimension line may cut or cross another dimension line where there is no other way.

Dimension to the hidden lines be avoided. (Fig 2)

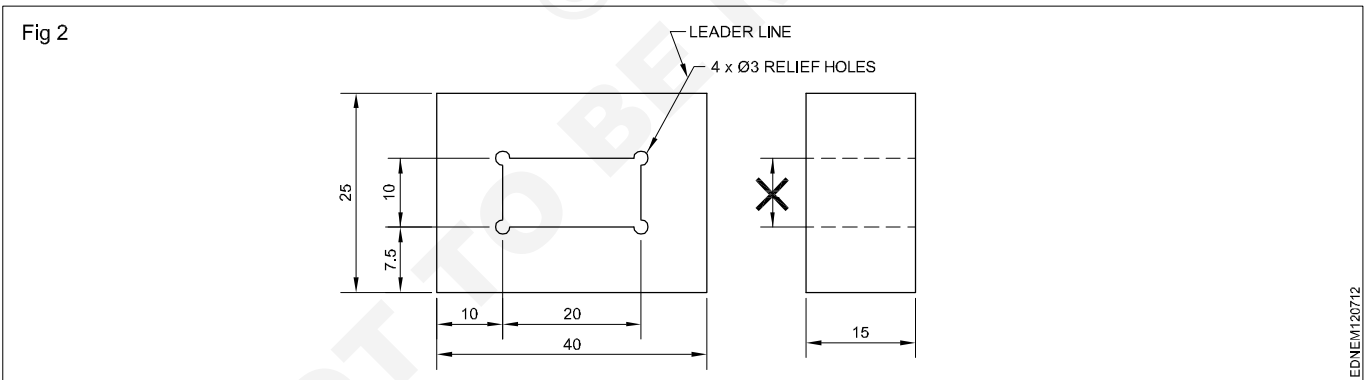

Arrowheads may be placed outside where space is insufficient.

Leader line: It is a thin continuous line. It connects a note or dimension with the features to which it applies. (Fig 2)

Termination and Origin indication: The terminations (arrowheads/oblique strokes) must be proportionate to the size of the drawing. Only one type of arrowhead may be used on a single drawing. However, where the space is too small for the arrowheads, they may be substituted by a dot or by an oblique line. Arrowheads are drawn as short lines with barbs at any conveniently

included angle between 15° and 90°. They may be open, closed or closed and filled in. Oblique strokes are drawn as short lines inclined at 45°. (Fig 1)

Indicating dimensional values on drawings: All dimensional values shall be shown on drawings in characters of sufficient size to ensure complete legibility on the original drawings as well as on reproductions made from micro-filming.

They shall be placed in such a way that they are not crossed or separated by any other line on the drawing.

Transferring measurement from the given object to the free hand sketches

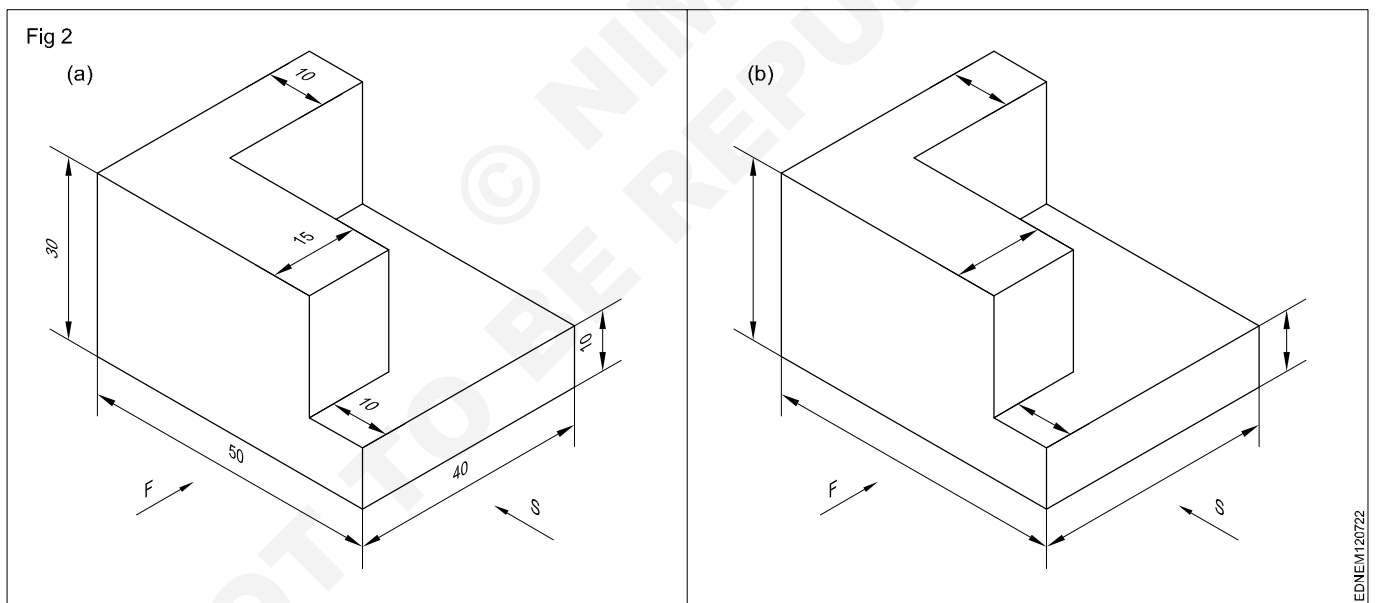
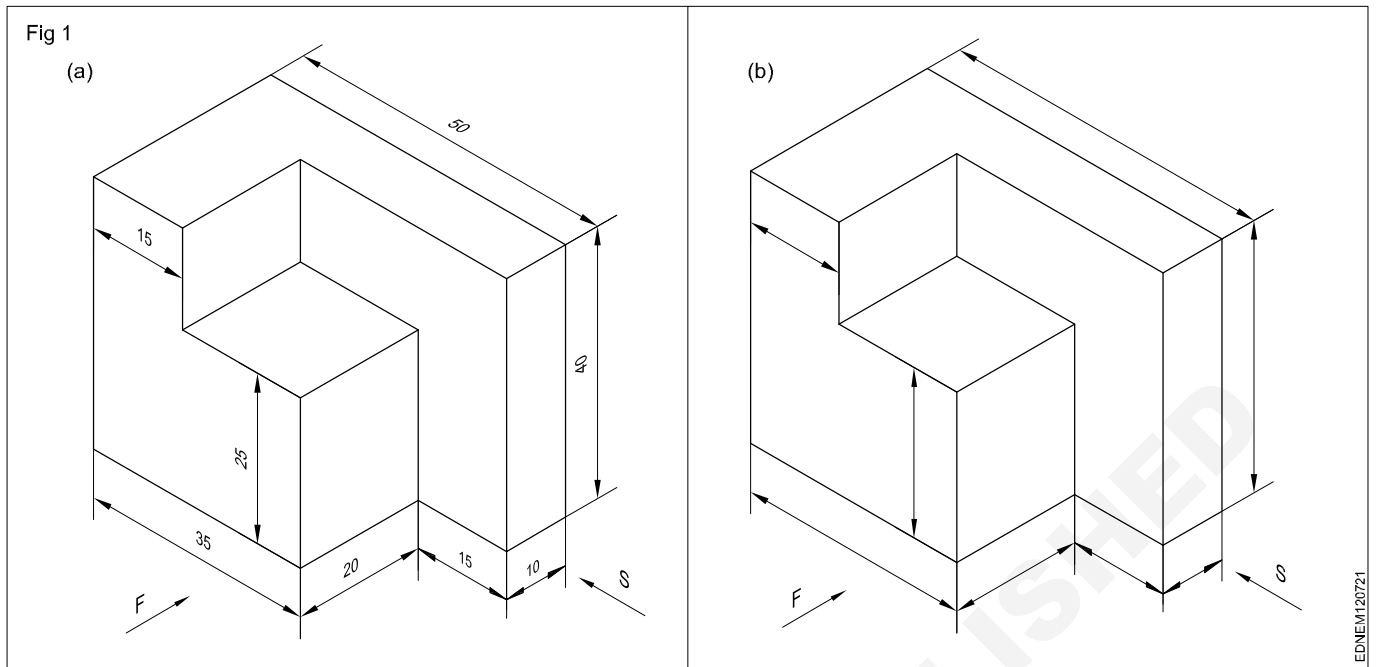
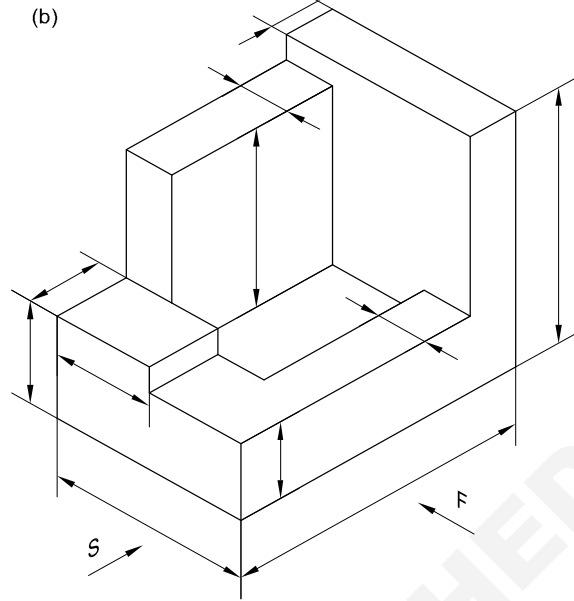
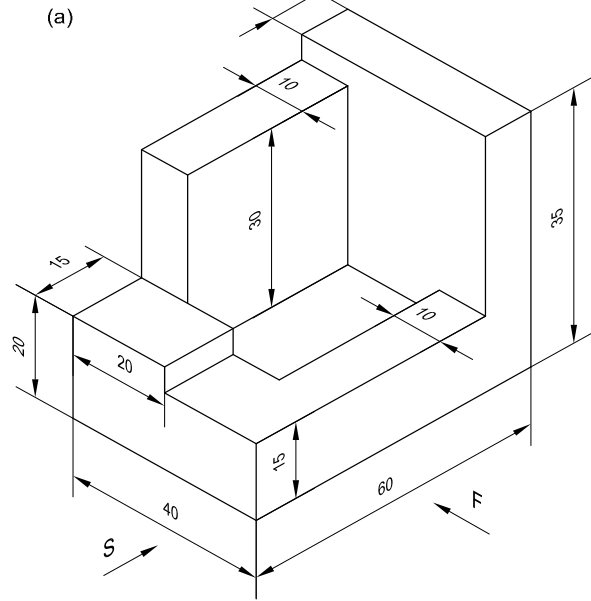
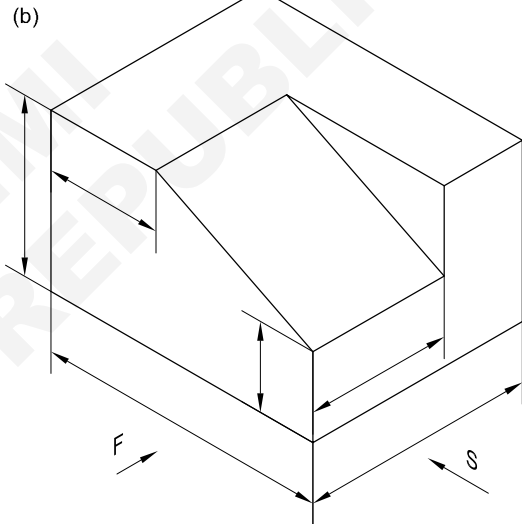
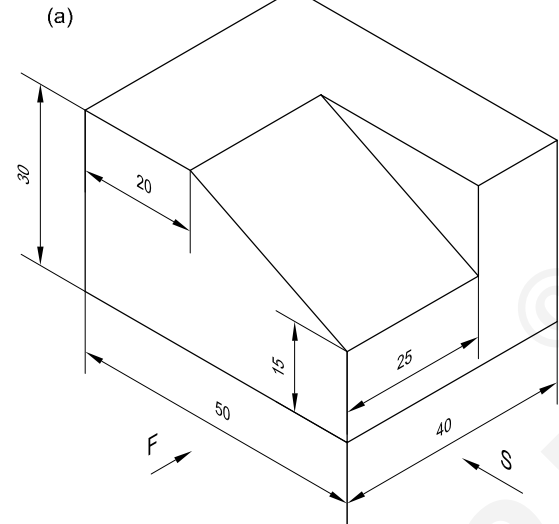

Fig 3



EDNEM120723

Fig 4



EDNEM120724

Fig 5

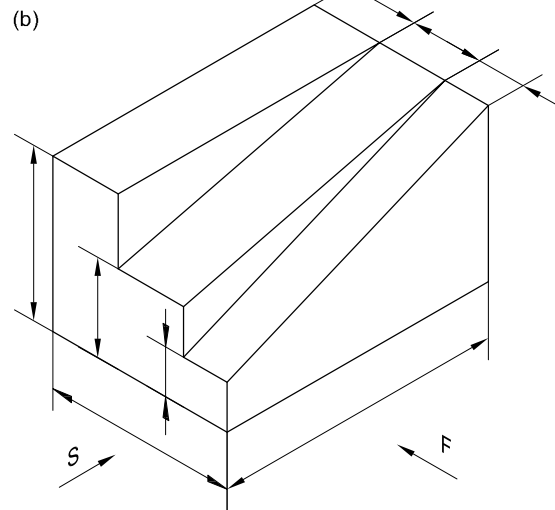
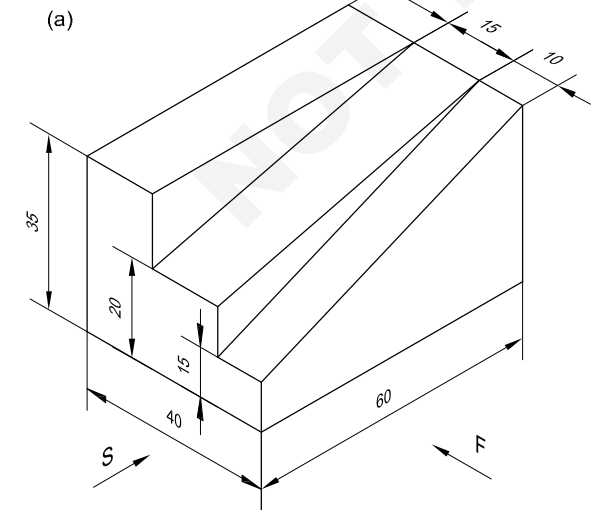

EDNEM120725

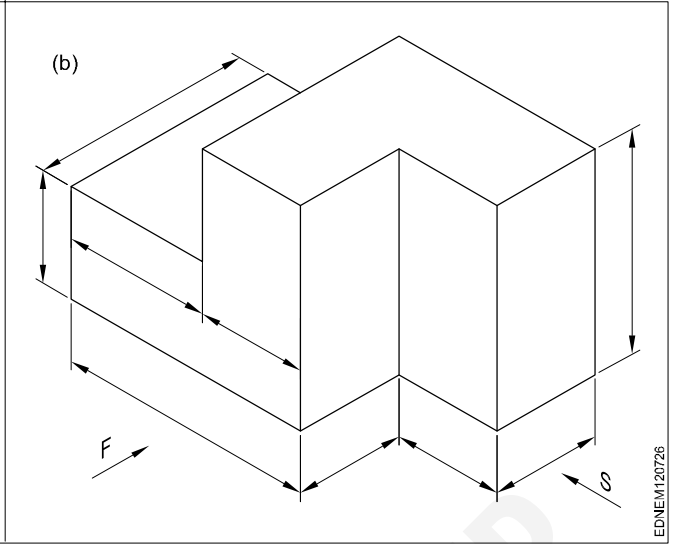
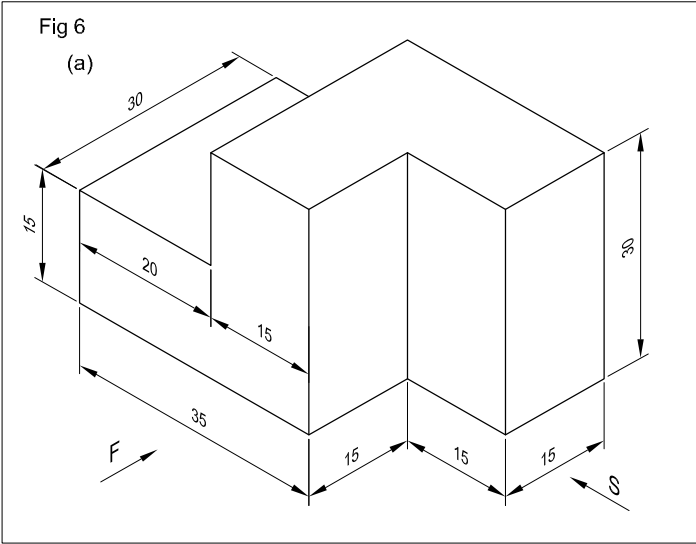

EDNEV120726

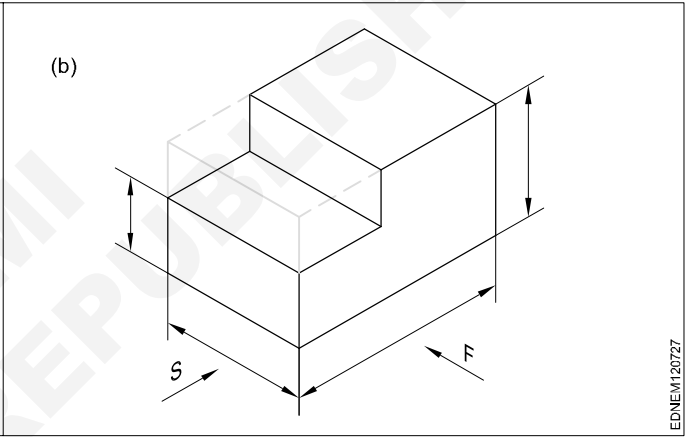
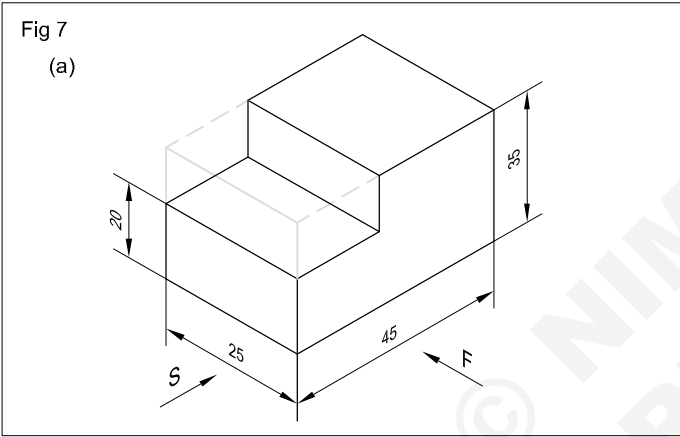

EDNEV120727

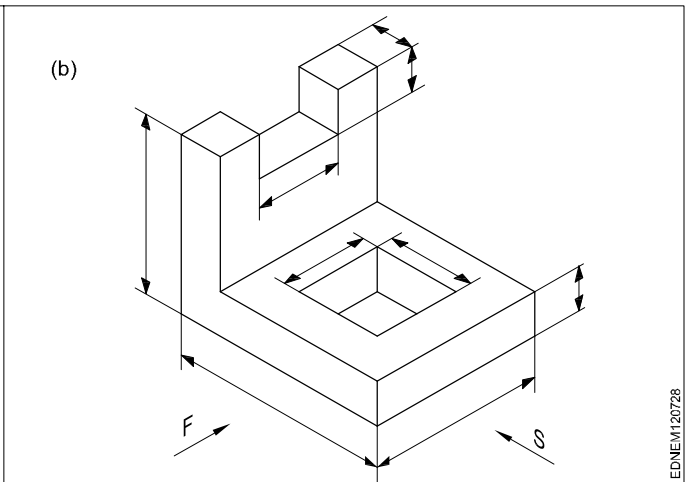
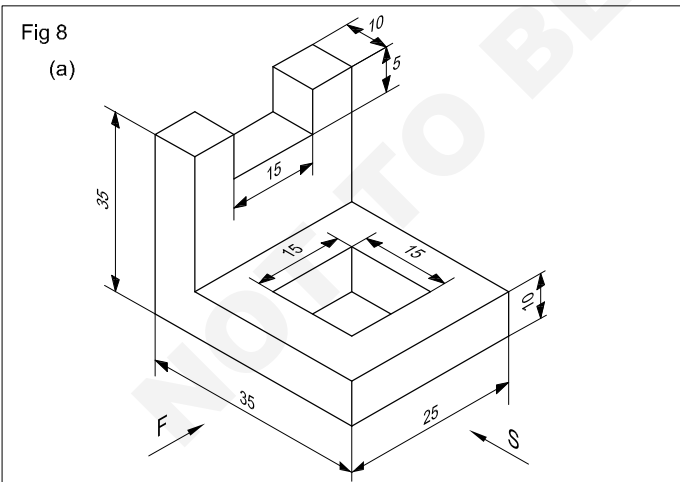

EDNEV120728

Fig 9

(a)

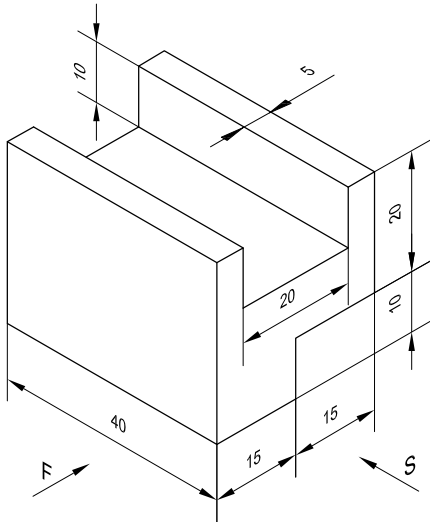

(b)

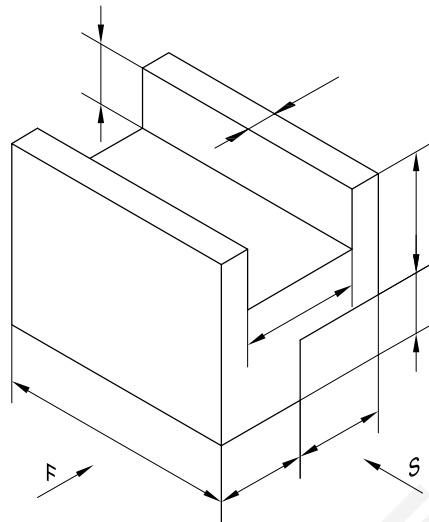

EDNEM120729

Fig 10

(a)

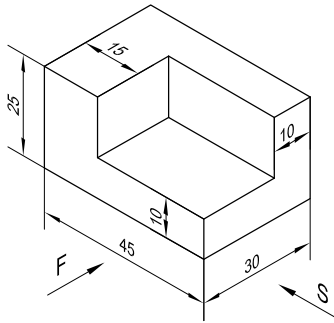

(b)

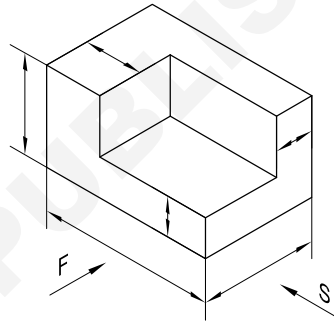

EDNEM12072A

Freehand drawing of hand tools

Hand Tools

Files (Fig 1)

- a Curved cut file
- b Rasp cut file
- c Single cut file
- d Double cut file

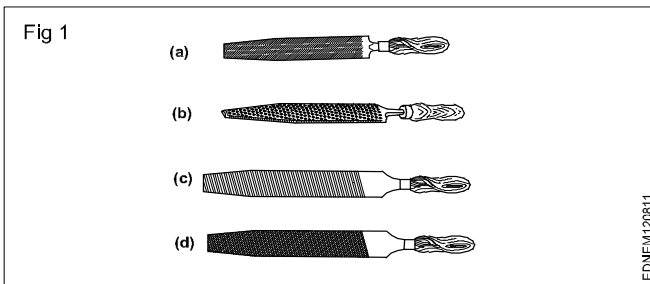

Hacksaw (Fig 2)

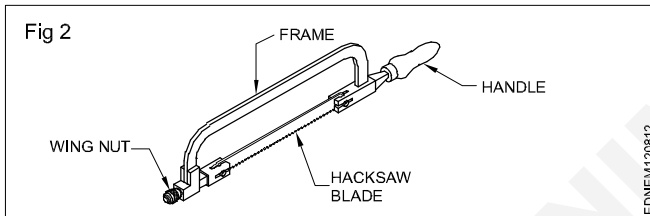

Ball pein hammer (Fig 3)

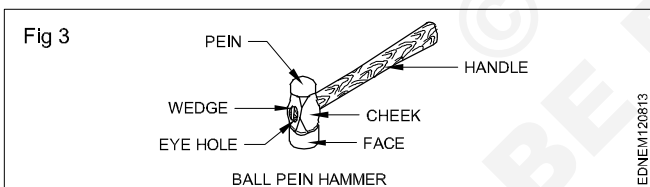

Chisel (Fig 4)

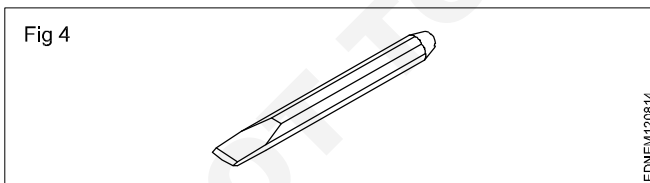

'C' clamp (Fig 5)

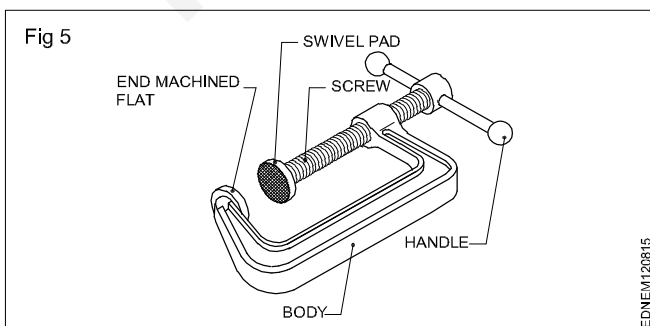

Screw driver (Fig 6)

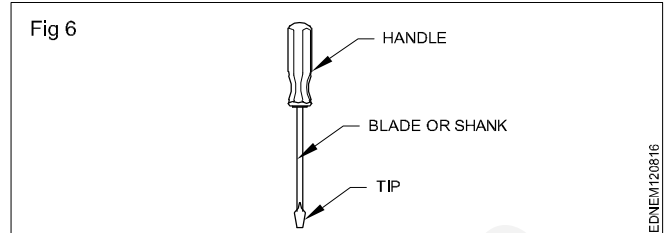

Bench vice (Fig 7)

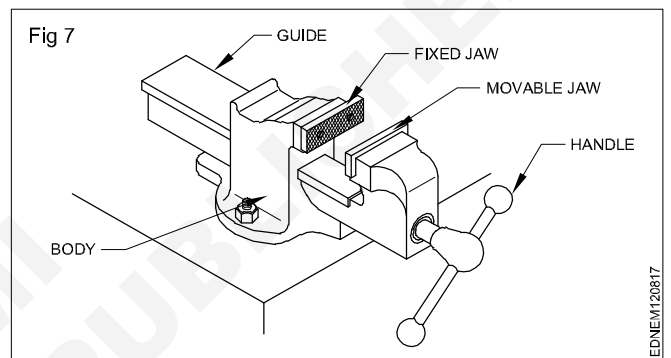

Cutting plier (Fig 8)

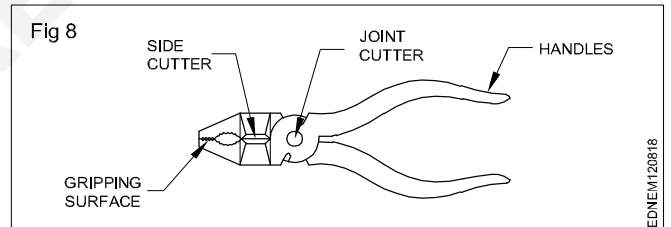

Open end spanner (Fig 9)

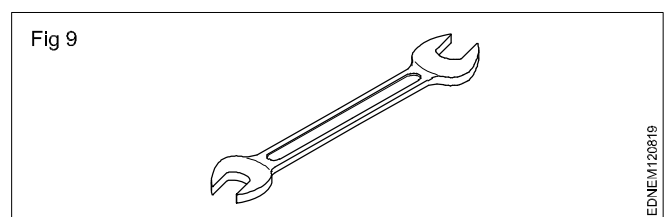

Measuring Tools

Steel rule (Fig 10)

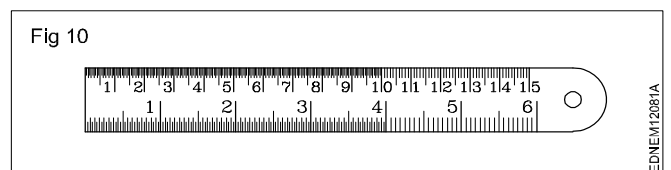

Try square (Fig 11)

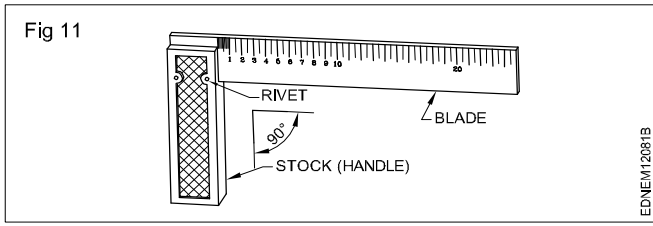

Feeler gauge (Fig 12)

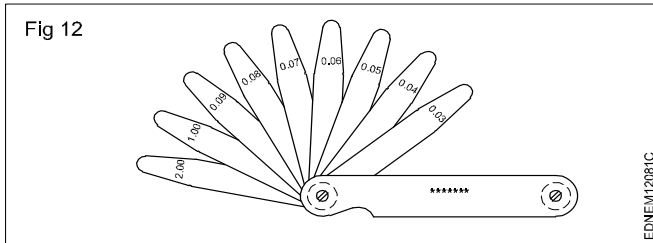

Hand Tools

Screw driver (Fig 13)

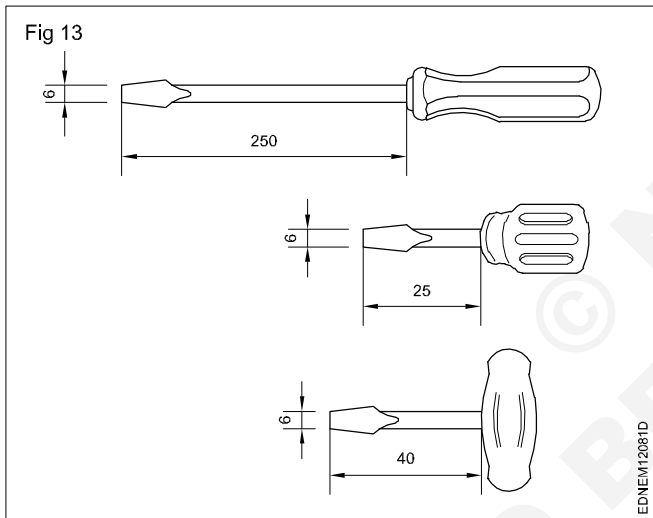

Screw driver with cross / star type tips (Fig 14)

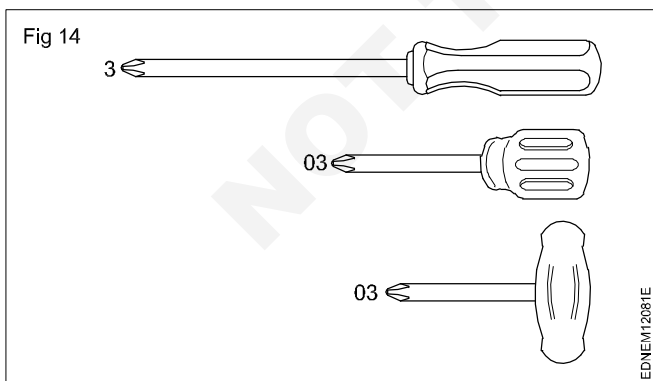

Screw tips aided screw heads (Fig 15)

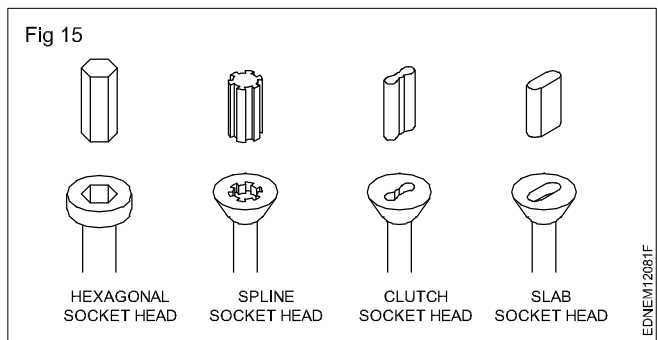

Instrument screw driver (Fig 16)

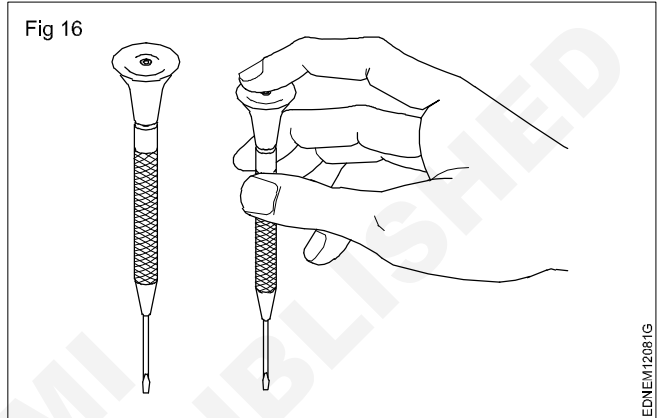

Screw driver interchangeable tips (Fig 17)

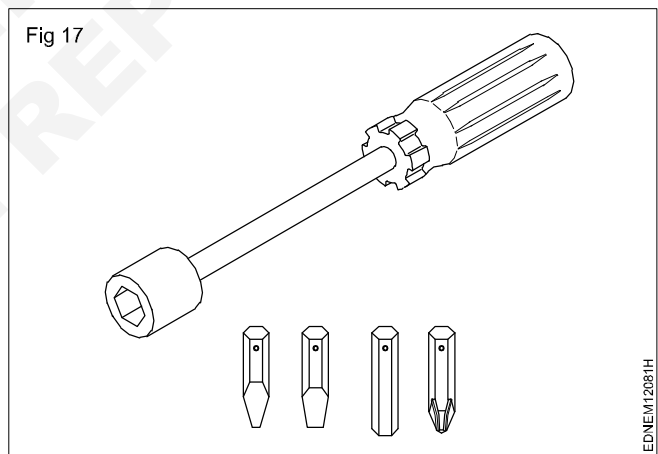

Special type screw driver (two rectangular recesses) (Fig 18a)

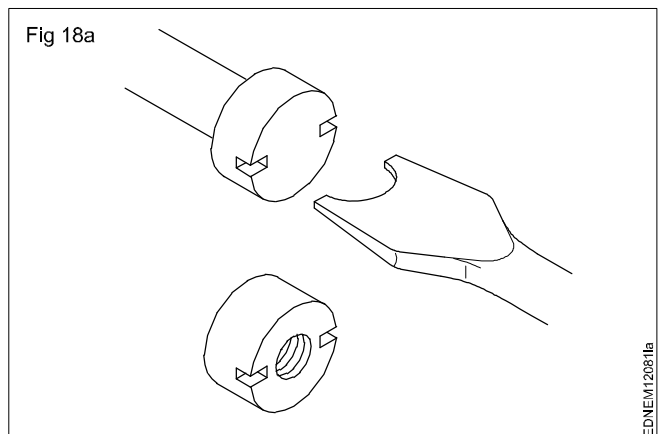

Special type screw driver (two round recesses) (Fig 18b)

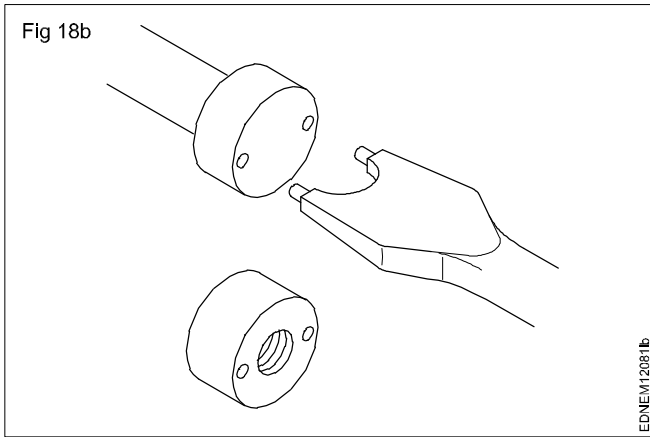

Soldering work station (Fig 22)



Analog multimeter (Fig 19)

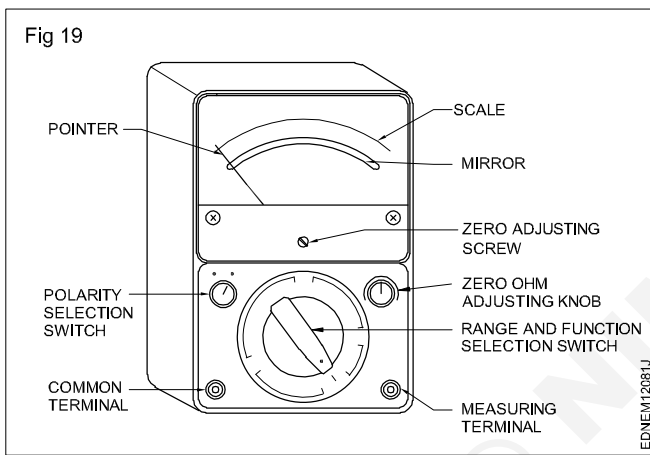

Ratchet brace (Fig 23)

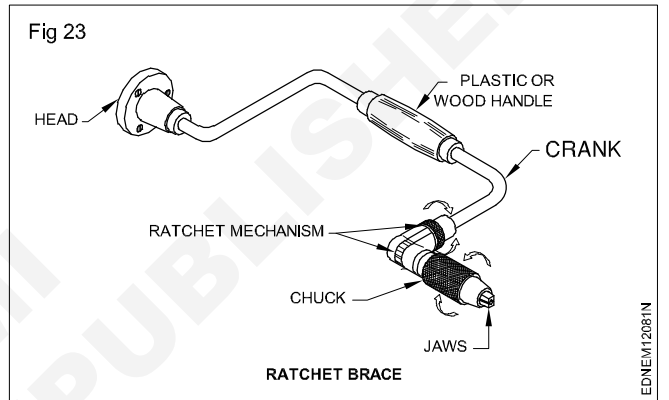

Neon Tester (Fig 24)

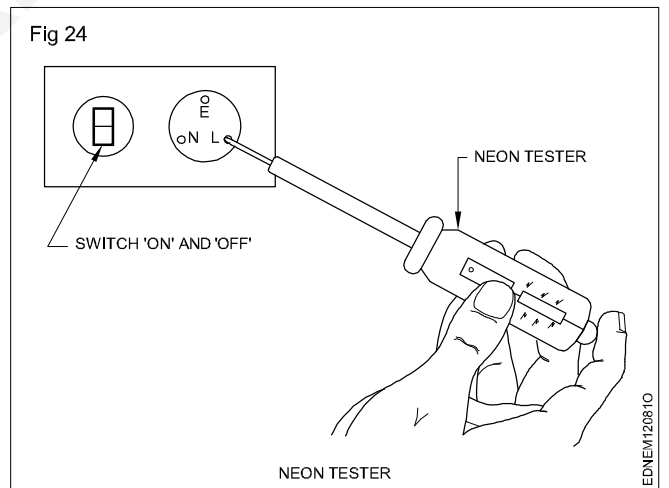

Pincers (Fig 20)

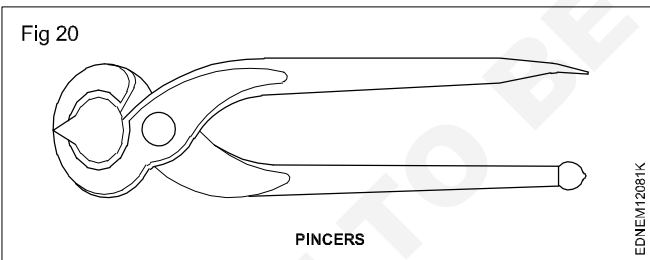

Soldering iron (Fig 21)

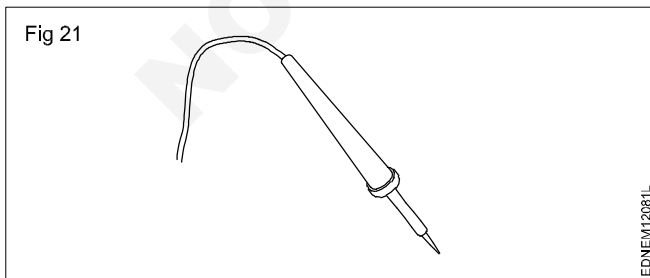

Gimlet (Fig 25)

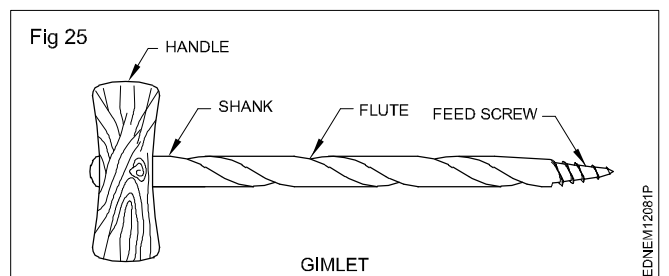

Electrician's knife (Fig 26)

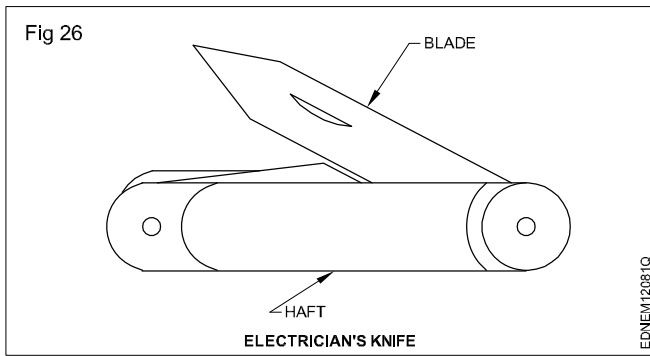

Mallet (Fig 27)

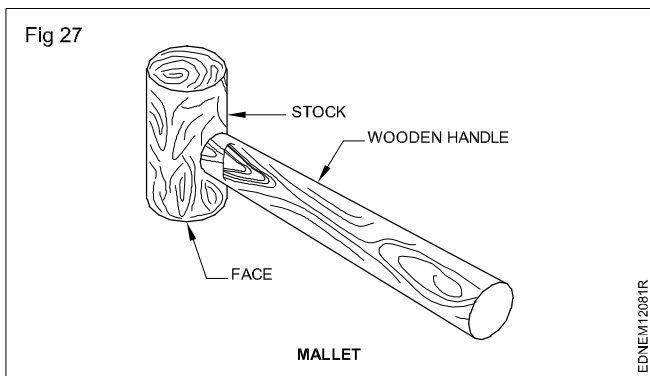

Electric drilling machine (Fig 28)

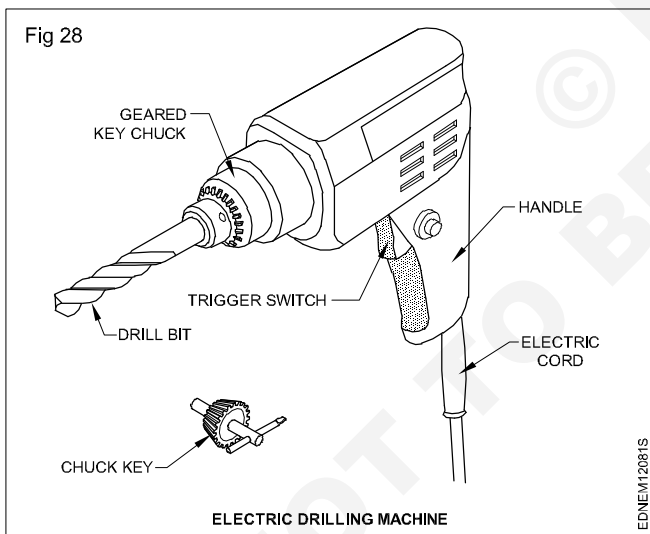

Hand drill (Fig 29)

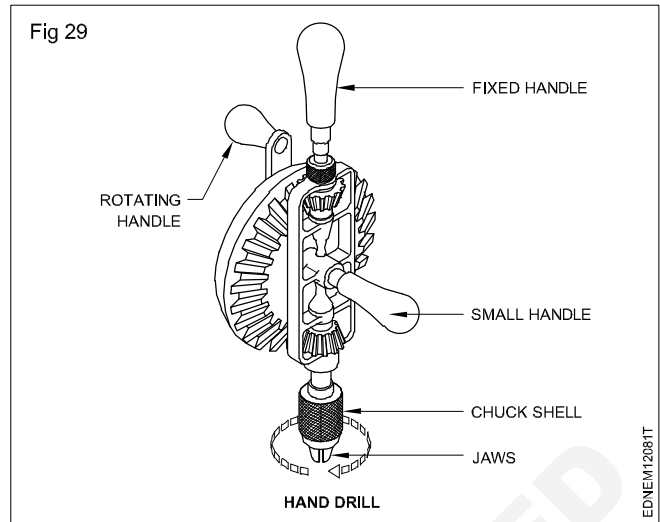

Rawl plug tool (Fig 30)

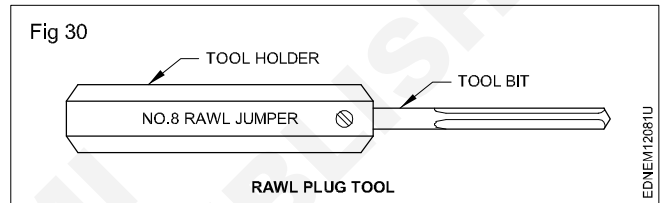

Pliers (Fig 31)

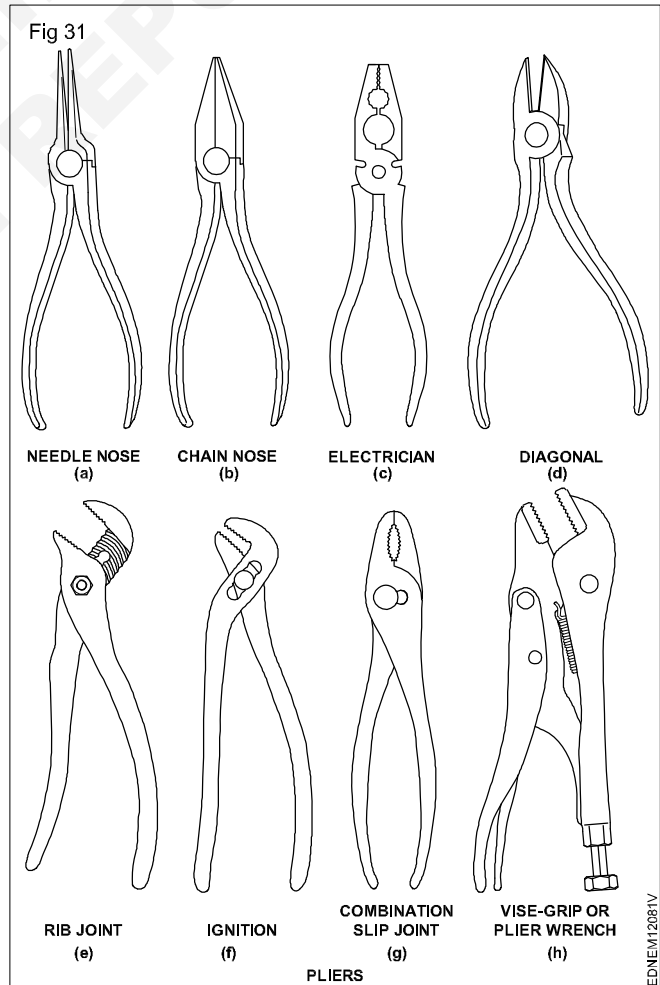

Tweezers (Fig 32)

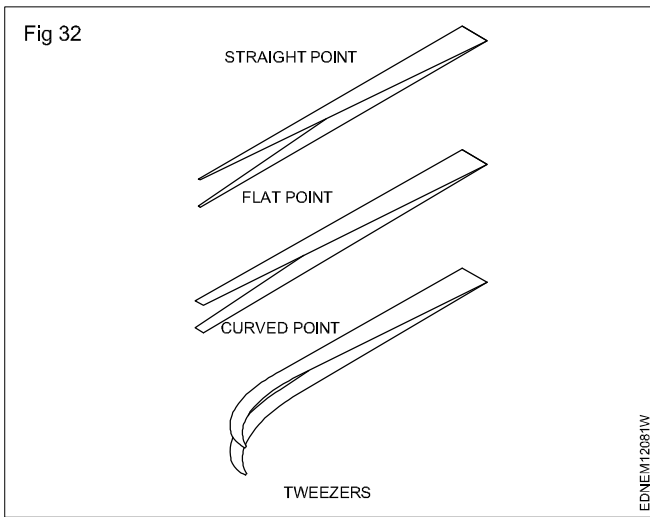

Stillson pipe wrench (Fig 35)

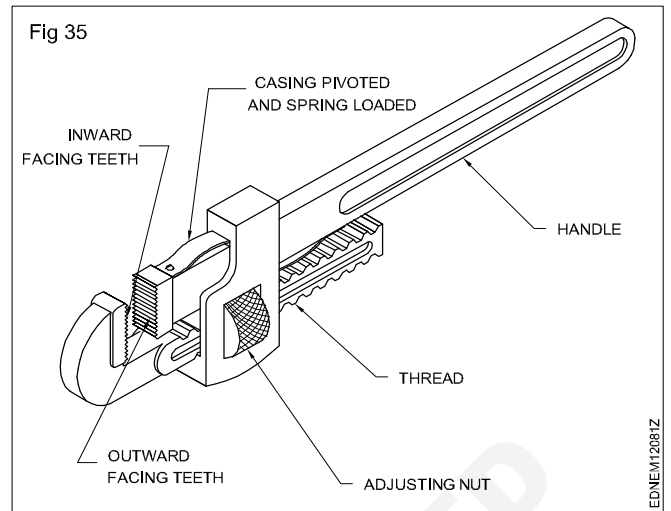

Socket extension bars (Fig 33)

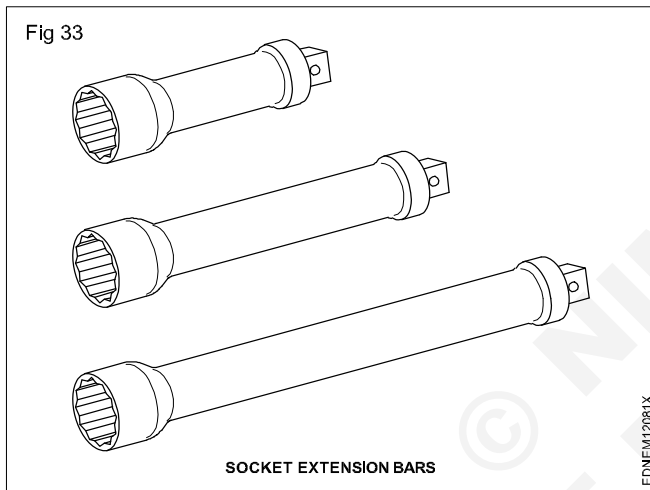

Puller (Fig 36)

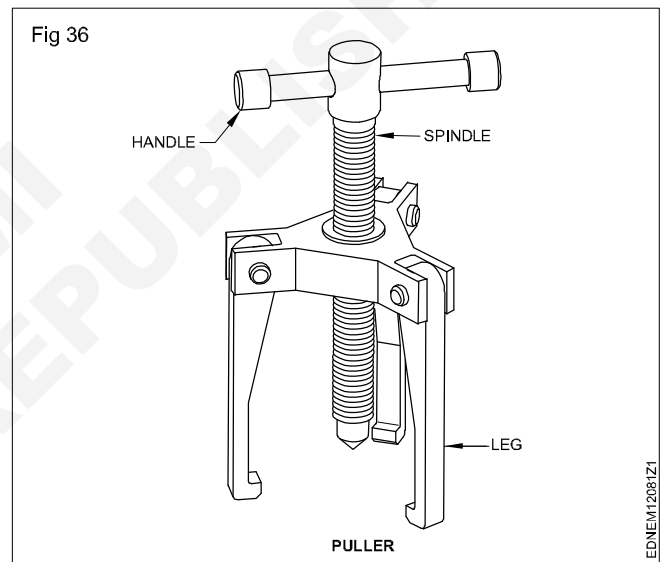

Round nose plier (Fig 34)

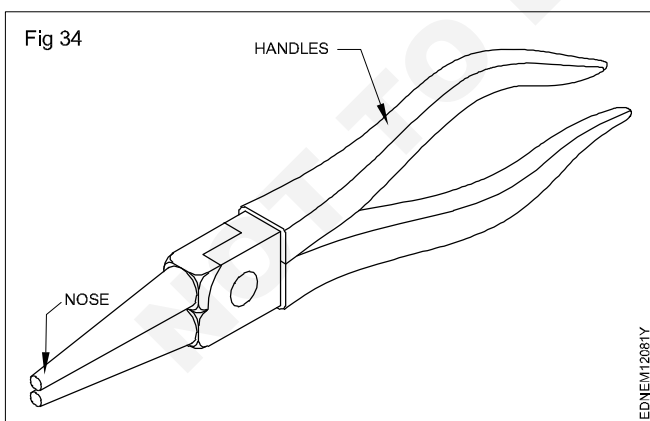

Standard wire gauge (Fig 37)

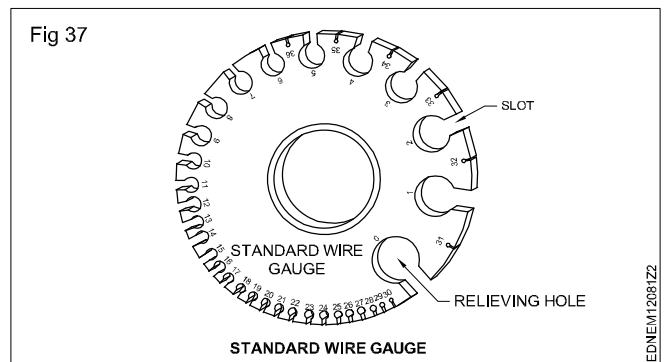

Pressure gauge (Fig 38)

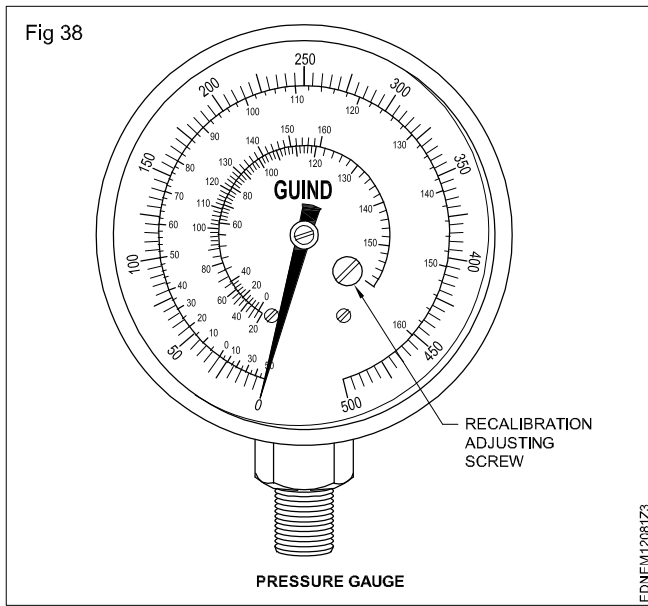

Flaring tool with yoke (Fig 39)

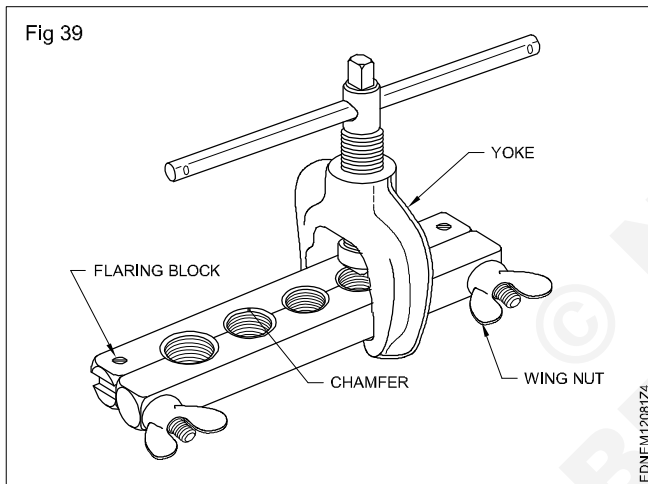

Mechanical type tube bender (Fig 40)

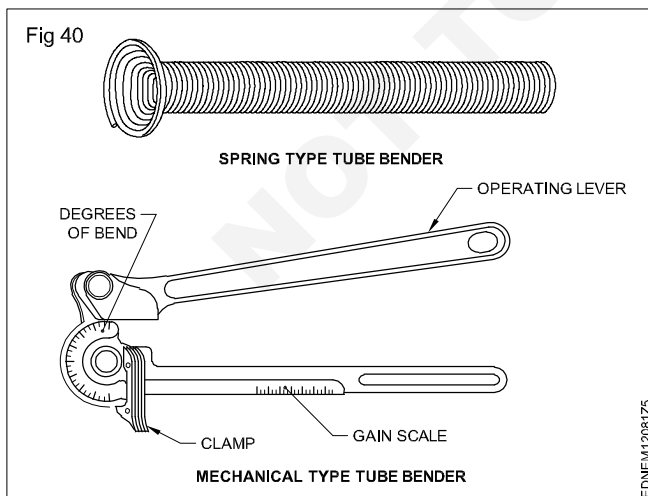

Built in type tube cutter (Fig 41)

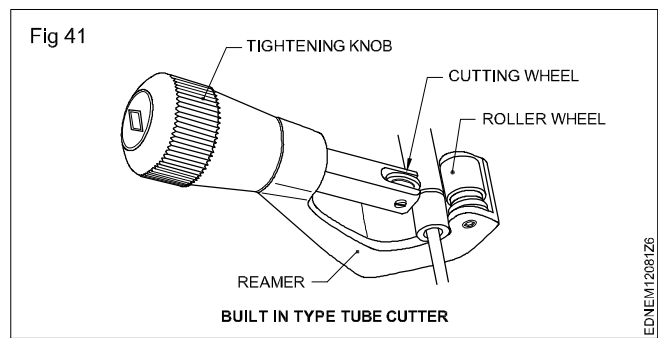

Swaging tools (Fig 42)

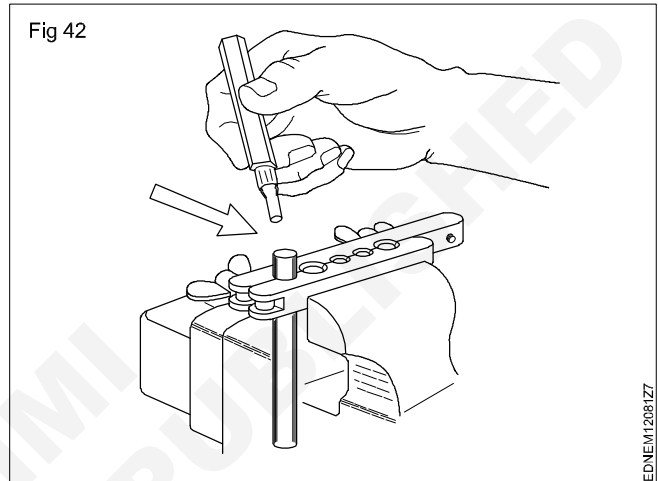

Tube cutter with reamer (Fig 43)

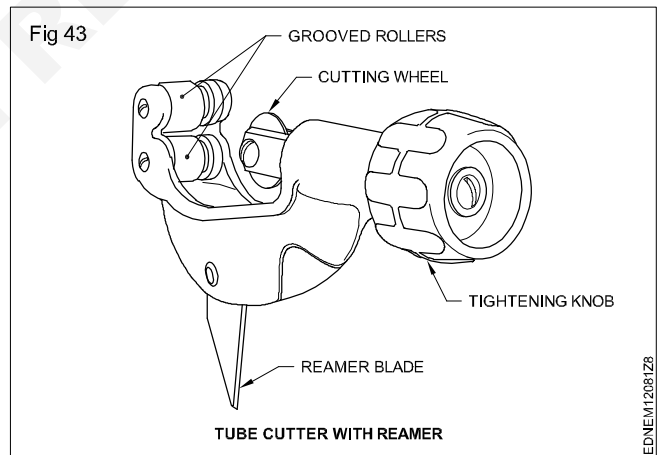

Accurate tube bender (Fig 44)

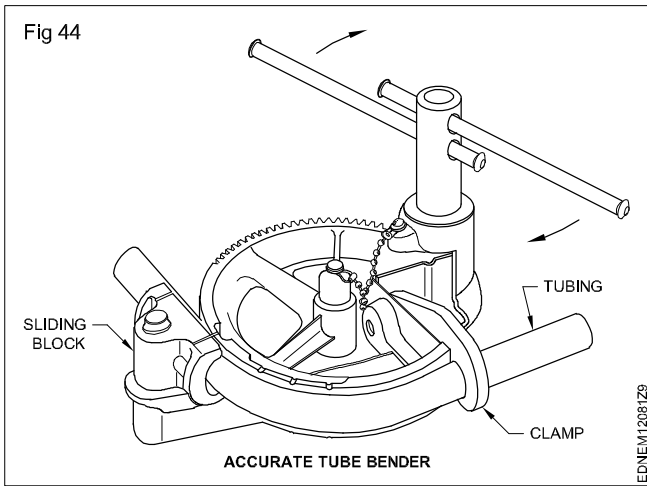

Depth micrometer (Fig 46)

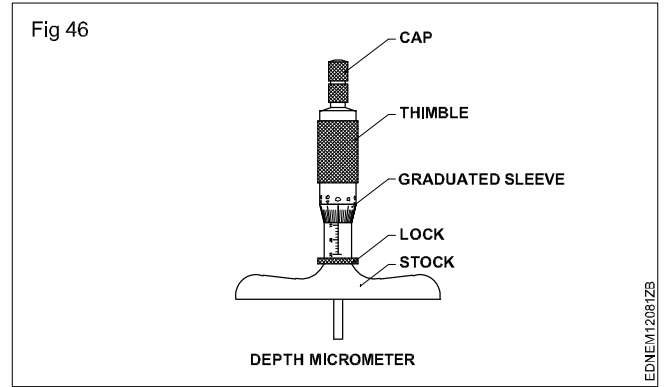

Vernier caliper (Fig 45)

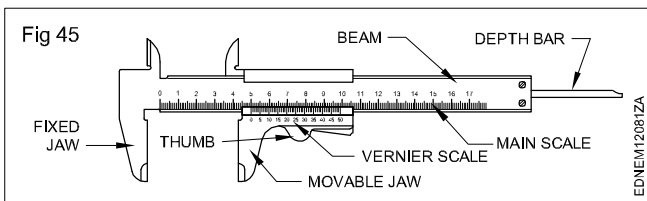

Micrometer (Fig 47)

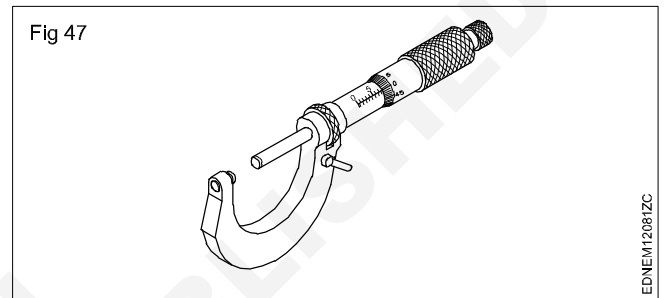

Drawing of geometrical figures - Angle & triangle

Angles: : Angle is the inclination between two straight lines meeting at a point or meeting when extended. AB and BC are two straight lines meeting at B. The inclination between them is called an angle. The angle is expressed in degrees or radians.

Concept of a degree: When the circumference of a circle is divided into 360 equal parts and radial lines are drawn through these points, the inclination between the two adjacent radial lines is defined as one degree. Thus a circle is said to contain 360°. (Fig 1)

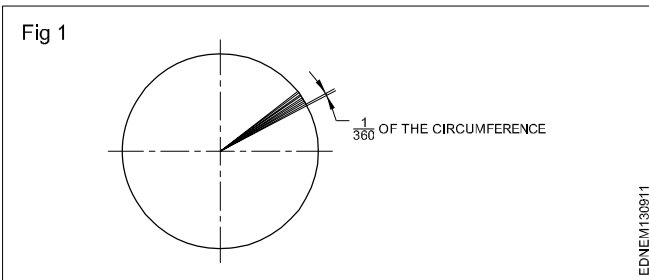

Acute angle: An angle that is less than 90° is called an acute angle. (Fig 2)

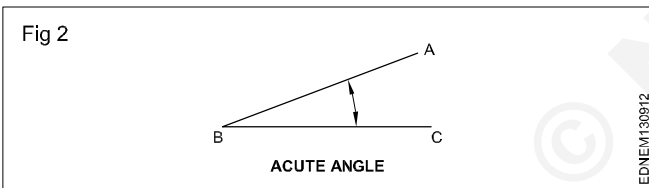

Right angle: The angle between a reference line and a perpendicular line is called a right angle. (Fig 3)

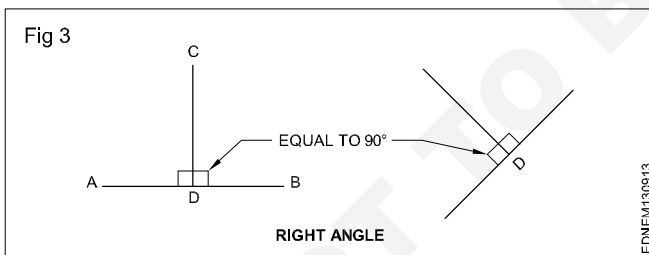

Obtuse angle: This refers to an angle between 90° and 180°. (Fig 4)

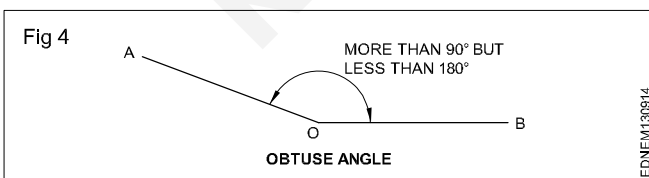

Straight angle: This refers to an angle of 180°. This is also called the angle of a straight line. (Fig 5)

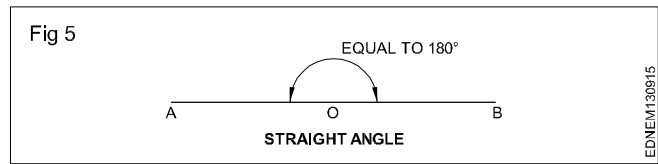

Reflex angle: It is the angle that is more than 180°, but less than 360°. (Fig 6)

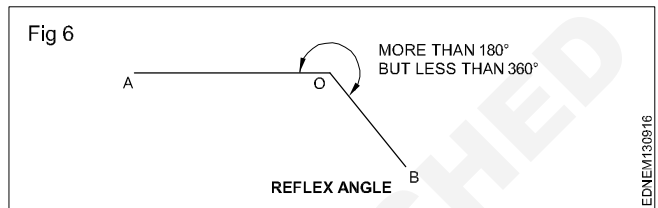

Adjacent angles: These are the angles lying on either side of a line. (Fig 7)

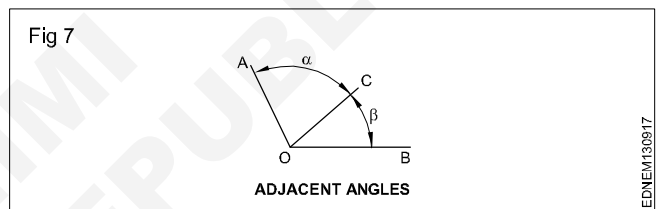

Complementary angles: When the sum of the two angles is equal to 90°, angle POQ + angle QOR = 90° angle POQ and angle QOR are complementary angles to each other. (Fig 8)

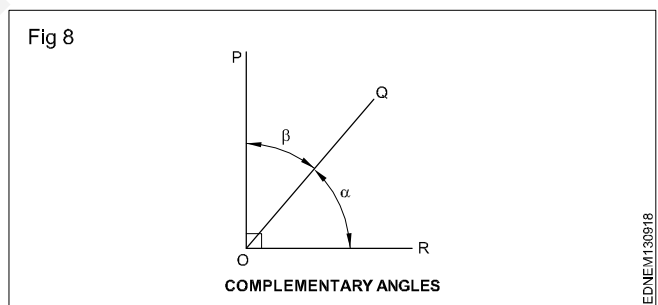

Supplementary angle: When the sum of the two adjacent angles is equal to 180°, for example, angle SOT + angle TOY = 180°, angle SOT and angle TOY are supplementary angles to each other. (Fig 9)

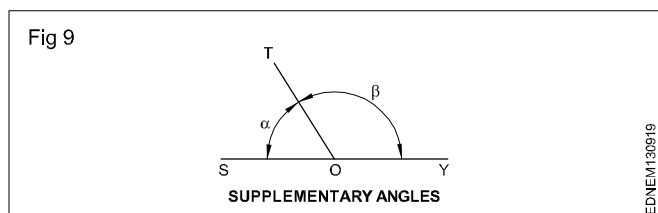

Triangle - different types

Triangle is a closed plane figure having three sides and three angles. The sum of the three angles always equals to 180° .

To define a triangle, we need to have a minimum of three measurements as follows:

- 3 sides or
- 2 sides and one angle or
- 2 angles and one side

Types of triangles

1 Equilateral triangle is a triangle having all the three sides equal. Also all the three angles are equal (60°). (Fig 1)

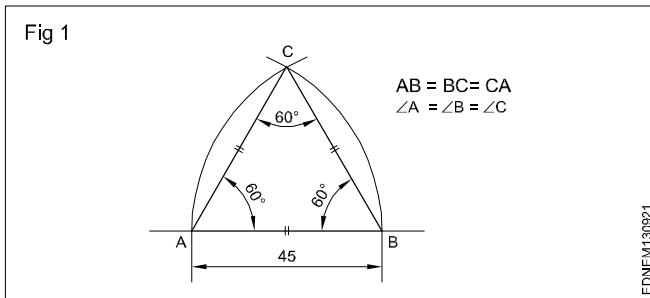

2 Isosceles triangle has two of its sides equal. The angles opposite the two equal sides are also equal. (Fig 2)

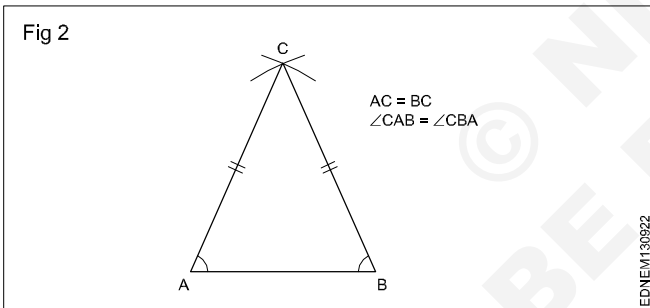

3 Scalene triangle has all three sides unequal in length. All three angles are also unequal. (Fig 3)

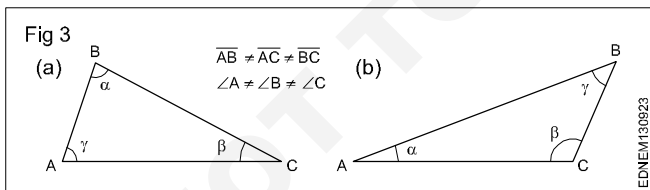

4 A right-angled triangle is one in which one of the angles is equal to 90° (Right angle). The side opposite the right angle is called the hypotenuse. (Fig 4)

5 An Acute angled triangle is one in which all the three angles are less than 90° . (Fig 5)

6 Obtuse angled triangle has one of the angles more than 90° . (Fig 6)

The sum of the three angles in any triangle is equal to 180° .

The sum of any two sides is more than the third side.

Fig 4

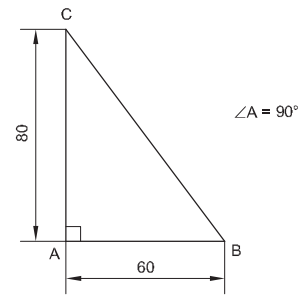

Fig 5

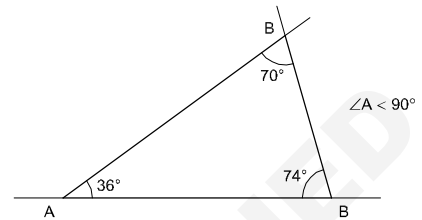
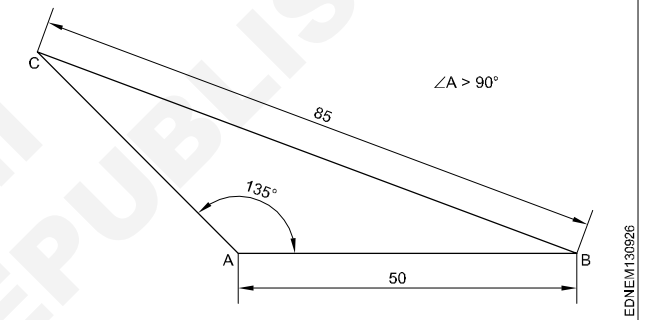

Fig 6



Procedure to draw the triangle

- 1 Equilateral triangle (Fig 1) $AB = BC = CA = 35$ mm.**
 - Draw a line and mark AB 35 mm side of the triangle.
 - Draw radius from centre A and B, arcs cutting mark at C (Fig 1).
 - Join CA and CB.
 - ABC is a required triangle.

Fig 1

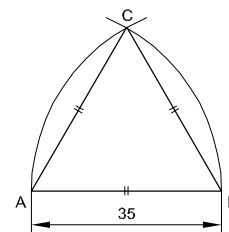

- 2 Isosceles triangle : $AB = AC = 60$ mm & $\angle BAC = 40^\circ$.**

- Draw the side AB equal to 60 mm. 'A' as the centre, draw an arc of radius AB.
- Draw a line AC at 40° to AB.
- Join BC to form the triangle ABC. (Fig 2)

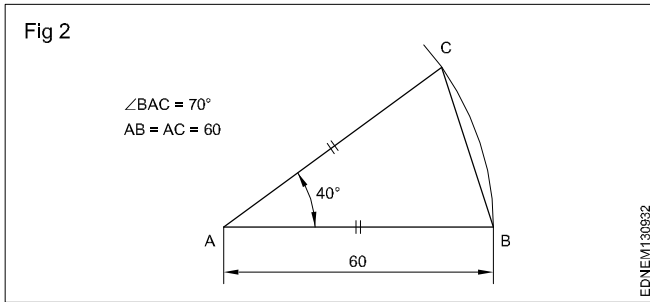

Exercise

1 Scalene triangle: $AB = 30$ mm, $AC = 55$ mm & $BC = 35$ mm. (Fig 1)

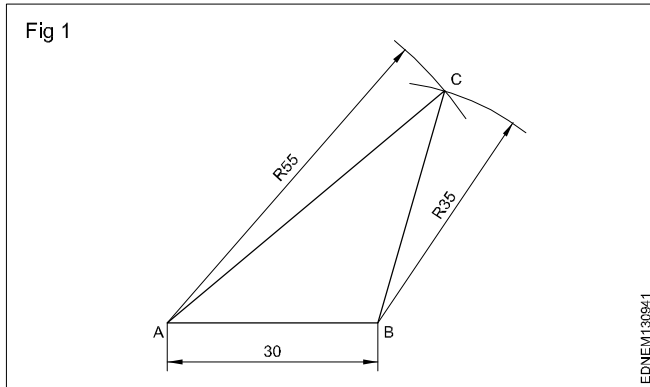

2 Scalene triangle: $AB = 70$ mm. (Fig 2)

$\angle ABC = 40^\circ$ & $\angle BAC = 110^\circ$

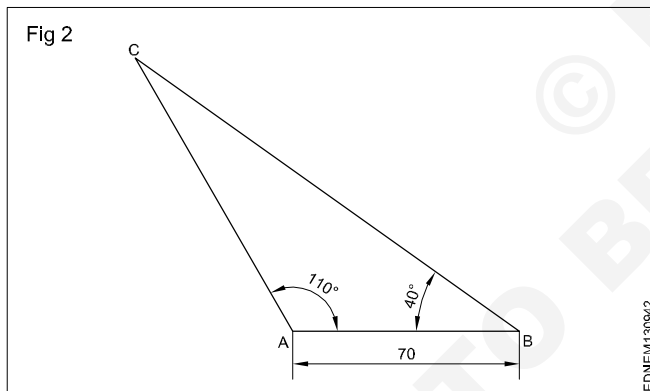

3 Right angled triangle: $AB = 60$ mm, $BC = 45$ mm. (Fig 3)

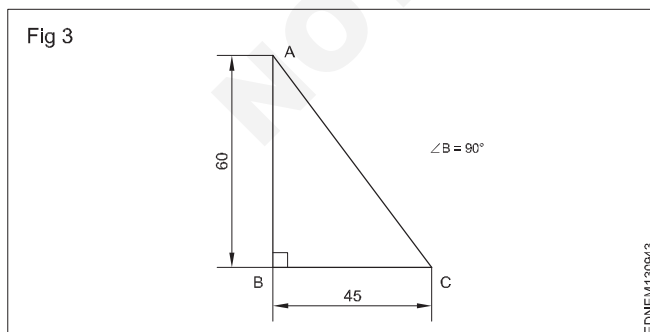

4 Draw a triangle when one side and 2 angles being given in Fig 4.

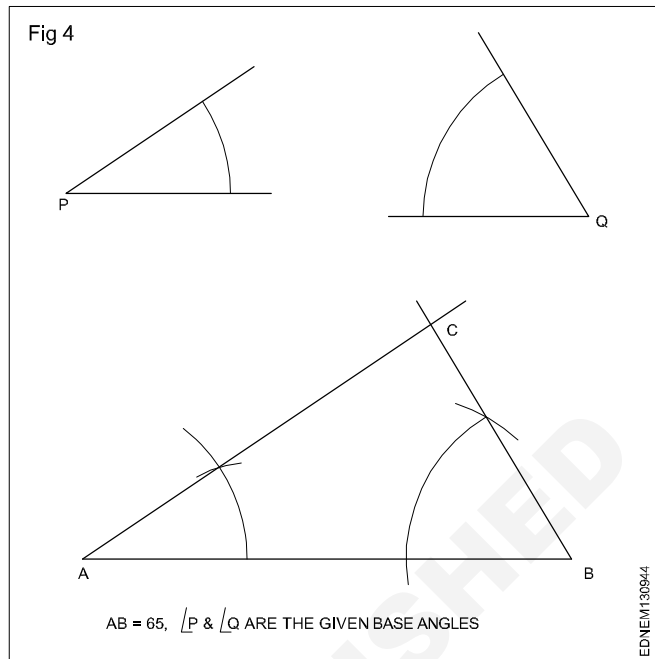

5 Draw a right angled triangle when the base and hypotenuse being given in Fig 5.

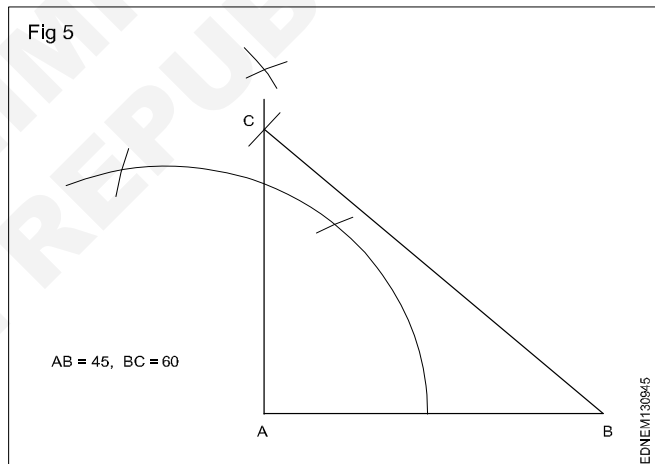

6 Draw a triangle with the altitude and two sides being given in Fig 6.

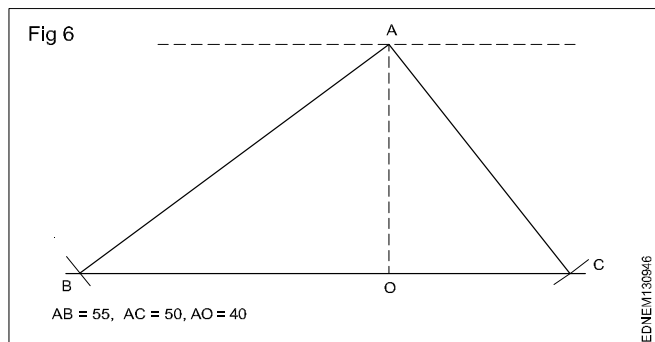

Drawing of geometrical figures - Circle

Circle: Circle is a plane figure bounded by a curve, formed by the locus of a point which moves so that it is always at a fixed distance from a stationary point the "Centre".

Radius: The distance from the centre to any point on the circle is called the "Radius".

Diameter: The length of a straight line between two points on the curve, passing through the centre is called the "Diameter". (D: Dia or d) It is twice the radius.

Circumference: It is the linear length of the entire curve, equal to πD .

Arc: A part of the circle between any two points on the circumference or periphery is called an 'Arc'.

Chord: A straight line joining the ends of an arc is called the chord. (Longest chord of the circle is the diameter)

Segment: A part of the circle or area bound by the arc and chord is the segment of the circle.

Sector: It is the part of a circle bounded by two radii (plural of radius) meeting at an angle and an arc.

Quadrant: Part of a circle with radii making 90° with each other is a quadrant (one-fourth of the circle).

Half of the circle is called a semi-circle.

Tangent: The tangent of a circle is a straight line just touching the circle at a point. It does not cut or pass through the circle when extended.

Fig 1 shows all the above elements.

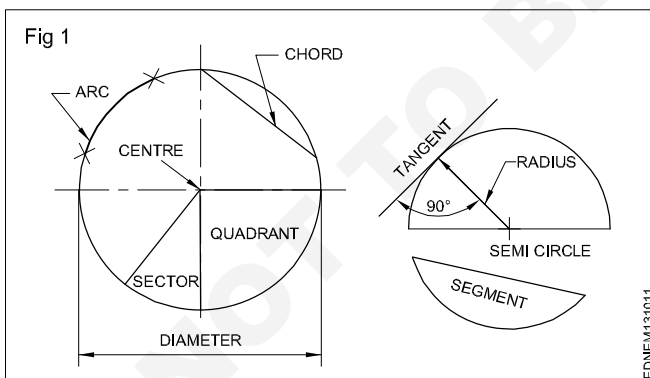

Concentric circles: When two or more circles (drawn) have a common centre, they are called concentric circles. Ball-bearing is the best example of concentric circles. (Fig 2)

Eccentric circles: Circles within a circle but with different centres are called eccentric circles. (Fig 3)

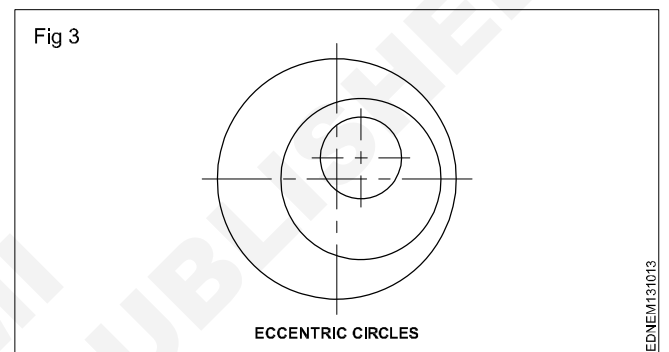
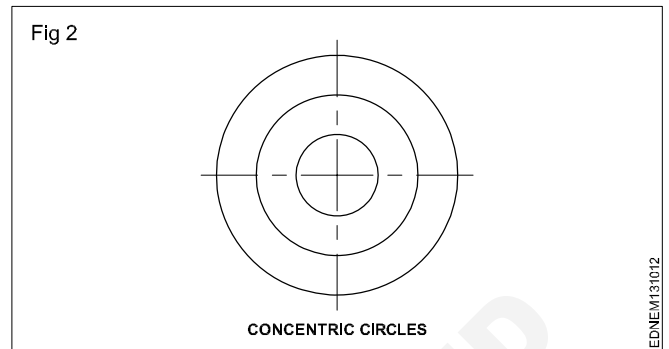

Circle and Arcs

Exercise

1 Draw a tangent to a given circle of ϕ 50 mm at any point 'P' on it. (Fig 1)

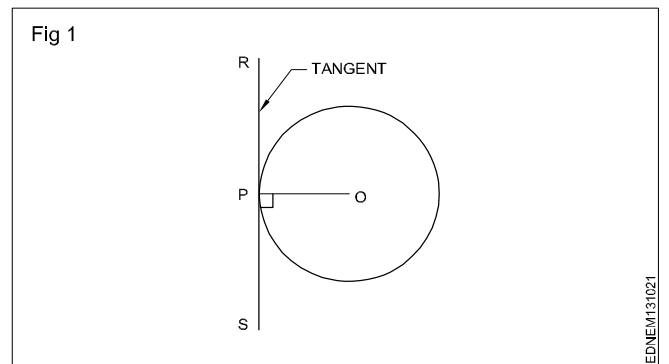

2 Draw a loop of 3 circles pattern. (Fig 2)

Draw any line MN and mark points A,B and C. So that AB = 20 mm and BC = 25 mm.

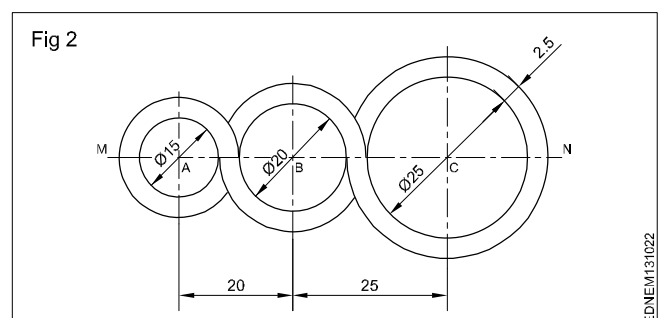

3 3 Draw three circles tangential to each other if centres A, B & C are given. (Fig 3)

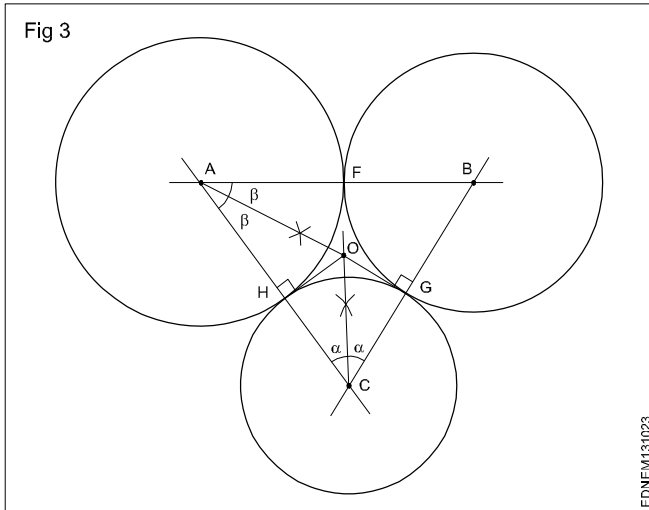

4 Draw external tangents to circles of dia 40 and 30 and centre distance 60 mm. (Fig 4)

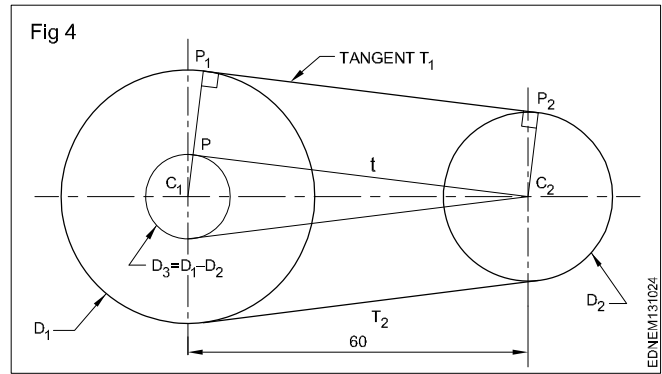

5 Draw internal tangents to circles of the same diameter 40 each and a centre distance of 60 mm. (Fig 5)

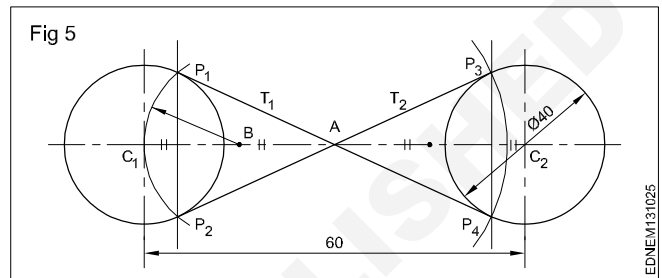

Drawing of geometrical figures - Square, rectangle and parallelogram

A quadrilateral is a plane figure bounded by four sides and four angles. The sum of the four angles in a quadrilateral is (interior angles) equal to 360° . The side joining opposite corners is called diagonal. To construct a quadrilateral out of four sides, four angles and two diagonals a minimum of five dimensions are required of which two must be sides. Quadrilaterals are also referred as Trapezium. (Fig 1)

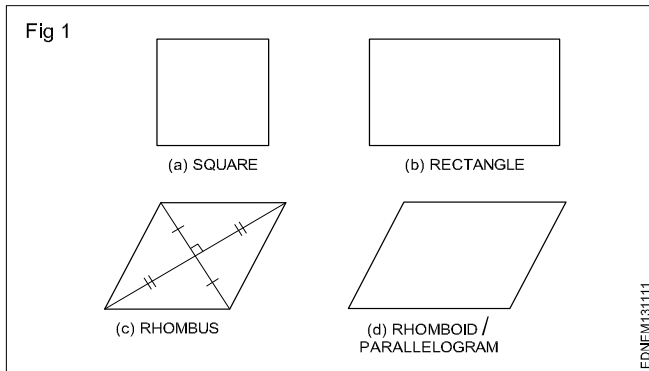

Types of quadrilaterals (Fig 1)

- Square
- Rectangle
- Rhomboid / Parallelogram

Square: In a square all the four sides are equal and its four angles are at right angles. The two diagonals are equal and perpendicular to each other.

Rectangle (Fig 2): In a rectangle, opposite sides are equal and parallel and all four angles are right angles.

Fig 2 shows a rectangle ABCD, Sides AB = DC and BC = AD. Diagonals AC and BD are equal. Diagonals are not bisected at right angles.

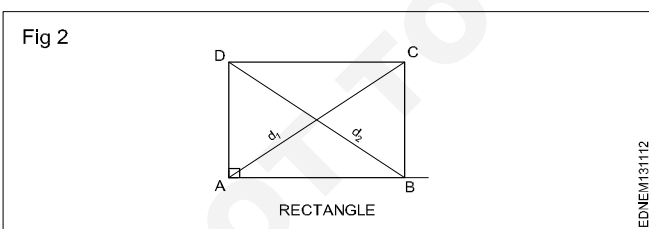

Rhomboid/Parallelogram (Fig 3): In a parallelogram, opposite sides are equal and parallel. Opposite angles are also equal. Diagonals are not equal but bisect each other.

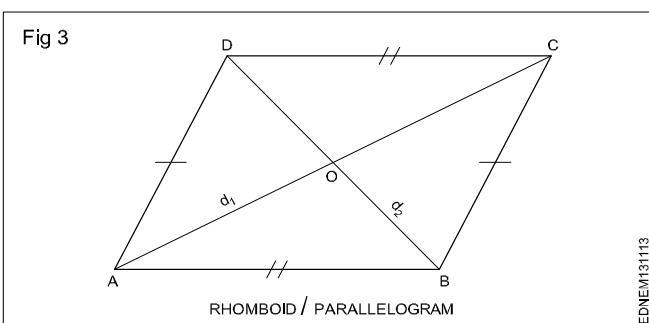

Procedure to draw the square, rectangle and parallelogram

Square

1 **1st method** (Fig 1): A square of side 50 mm by erecting perpendicular using compass and 45° set square.

Draw a line 50mm. 'A' as centre draw an arc of convenient radius. Same arc cut and mark as PQR. Draw a line perpendicular, mark 50mm and make a square as shown in figure.

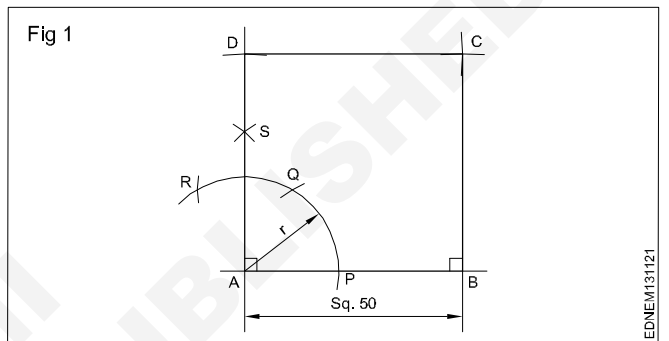

2 **2nd method** (Fig 2): A square of side 60 mm using 45° setsquare and compass.

Draw a horizontal line AB = 60 mm. From point 'A' & 'B' using 45° setsquare draw diagonal and circle of radius OA with centre 'O'. Join points AD, DC & CB to complete the required square.

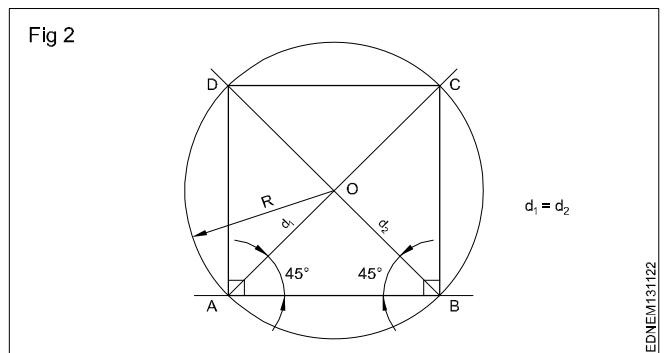

3 **3rd method** (Fig 3): A square of side 60 mm long by erecting perpendicular and also using 45° setsquare. Mark AD, BC and join ABCD to get the required square.

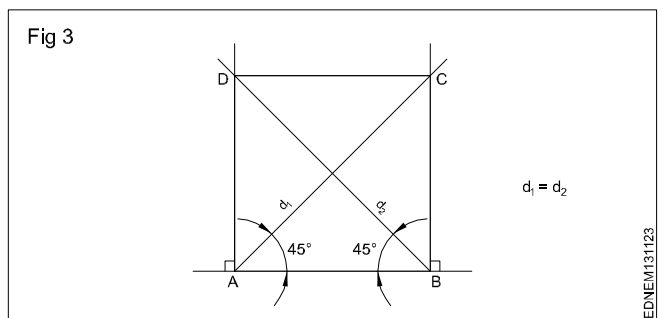

4 Square having diagonal 60 mm (Fig 4)

Draw horizontal and vertical centre lines intersect at 'O' and make a circle. Join all the points ABC&D to get the required square.

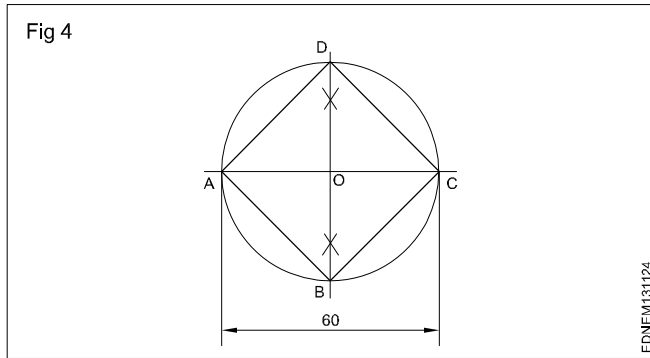

5 Rectangle (Fig 5)

Draw AB = 75 mm and side AD = 45 mm using setsquare and compass. Draw BC = 45 mm using setsquare and compass. Join ABCD to get the required rectangle.

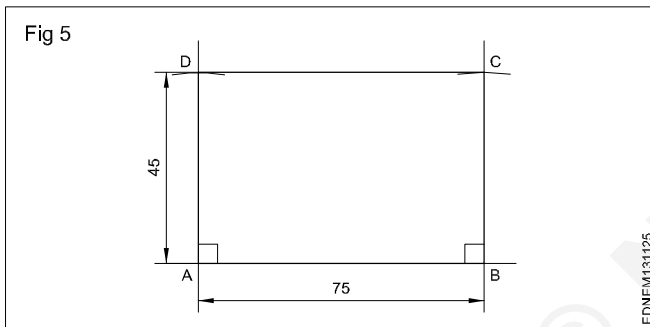

6 Rectangle - Diagonal - 60 mm and one side 20 mm 1st method (Fig 6a)

2nd method (Fig 6b)

ADBC is the required rectangle of side 20 mm and diagonal 60 mm by using setsquare and compass.

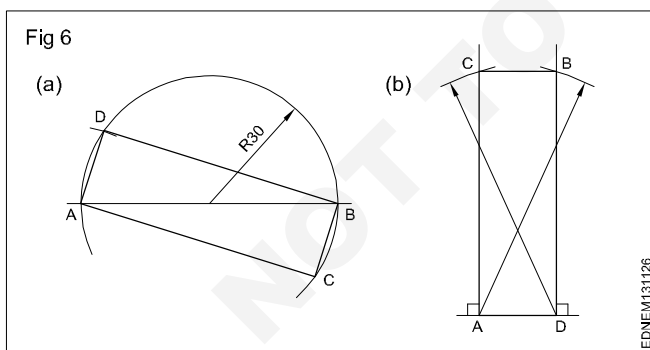

7 Parallelogram (Fig 7)

Sides = 75 mm and 40 mm, angle 50°

- Draw line AD equal to 40 mm and 50° angle to AB.
- 'D' as centre, draw an arc of radius equal to AB.
- 'B' as centre, draw an arc of radius equal to AD, upwards such that they meet at a point 'C'. Join ABCD to get the required parallelogram.

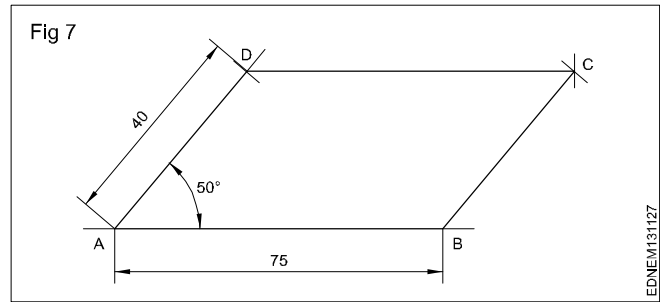

8 Parallelogram (Fig 8)

Parallelogram - Side AB = 60 mm

Diagonal AC = 90 mm $\angle ABC = 120^\circ$

- Draw a line AB = 60 mm. Draw a line from B to an angle 120° to AB.
- 'A' as centre with radius 90 mm, draw an arc cutting 120° line from 'B' at 'C'.
- 'C' as centre, radius = AB, draw an arc.
- 'A' as centre and BC as radius, draw another arc, both arcs meet at 'D'. Join AD and DC.

ABCD is the required parallelogram.

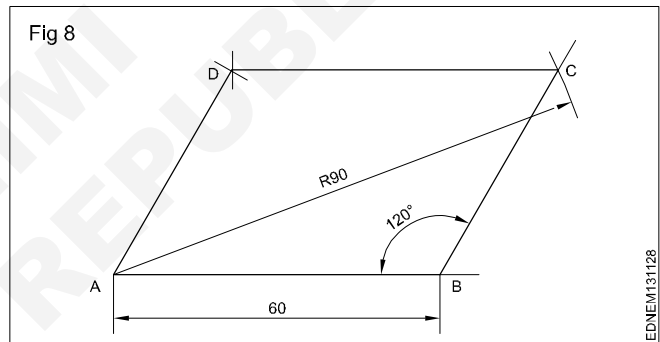

9 Parallelogram (Fig 9)

Sides AB = 55 mm, BC = 40 mm and vertical height = 30 mm.

- Draw the line AB = 55 mm long.
- 'A' and 'B' as centres and radius (R) 30 mm, draw arcs above the line.
- Draw a parallel tangential line to AB touching the arcs.
- 'A' and 'B' as centres, draw an arc of 40 mm radius cutting the line at 'D' and 'C'.

ABCD is the required parallelogram.

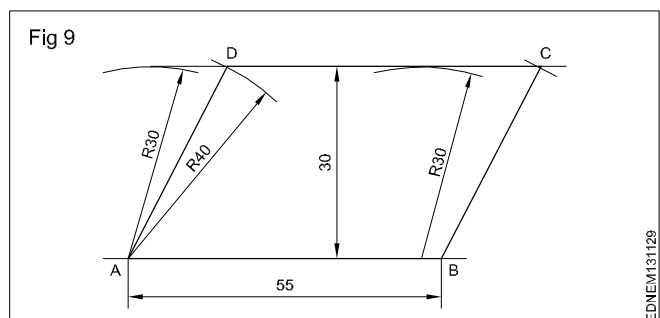

Lettering and numbering - Single stroke

Styles of lettering: Many styles of lettering are in use today. However, a few styles which are commonly used are shown in Fig 1.

Fig 1

ABCDEFGH abcdefgh	GOTHIC ALL LETTERS HAVING THE ELEMENTARY STROKES OF EVEN WIDTH ARE CLASSIFIED AS GOTHIC
ABCDEFGH abcdefgh	ROMAN ALL LETTERS HAVING THE ELEMENTARY STROKES "ACCENTED" OR CONSISTING OF HEAVY AND LIGHT LINES ARE CLASSIFIED AS ROMAN
<i>ABCDEFGH</i> <i>abcdefgh</i>	ITALIC ALL SLANTING LETTERS ARE CLASSIFIED AS ITALIC. THESE MAY BE FURTHER DESIGNATED AS ROMAN-ITALICS, GOTHIC-ITALICS, TEXT-ITALICS
ABCDEF abcde	TEXT THIS TERM INCLUDES ALL STYLES OF OLD ENGLISH, GERMAN TEXT, BRADELY TEXT OF OTHERS OF VARIOUS TRADE NAMES. TEXT STYLES ARE TOO ILLEGIBLE FOR COMMERCIAL PURPOSES

EDNEM131211

Standard heights/Width: The standard heights recommended by BIS SP: 46-2003 are in the progressive ratio of "square root 2". They are namely 2.5 - 3.5 - 5 - 7 - 10 - 14 and 20 mm. The height of lower case letter (without tail or stem) are 2.5, 3.5, 5, 7, 10 and 14 mm.

There are two standard ratios for the line thickness "d". They are A & B. In A = line thickness (d) is h/14 and in B=line thickness (d) is h/10.

Lowercase means small letters, as opposed to capital letters. The word yes, is for example, is in **lowercase**, while the word YES is in **upper case**. For many programmes, this distinction is very important. Programmes that distinguish between **uppercase** and **lowercase** are said to be case sensitive

The width of different letters in terms of "d" is as follows:

Lettering A

Width (W)	Capital letters	Width
1	I	1d
5	J,L	5d
6	C,E,F	6d
7	B,D,G,H,K,N,O,P,R,S,T,U & Z	7d
8	A,Q,V,X,Y	8d
9	M	9d
12	W	12d

Lower case letters and numerals

Width (W)	Letters/Numerals	Width
1	i	1d
3	j,l	3d
4	f,t,l	4d
5	c,r	5d
6	a,b,d,e,g,h,k,n,o,p,q,s,u,v;3;5	6d
7	a,0 (zero), 2,4,6,7,0,8,9	7d
9	m	9d
10	w	10d

The width of different letters in terms of stroke (line) is as follows:

Uppercase Lettering BIS SP: 46-2003

Width (W)	Capital letters
1	I
4	J
5	C,E,F,L
6	B,D,G,H,K,N,O,P,R,S,T,U & Z
7	A,M,Q,V,X,Y
9	W

Lower case letters and numerals

Width (W)	Letters/Numerals
1	i
2	l
3	j,l
4	c,f,r,t
5	a,b,d,e,g,h,k,n,o,q,s,u,v,x,y,x 0,2,3,5 to 9
6	0,2,3,5 to 9 a,4

Spacing of letters: Recommended spacing between characters, a minimum spacing of baselines and minimum spacing between words as per BIS SP: 46-2003 are given below in Fig 2.

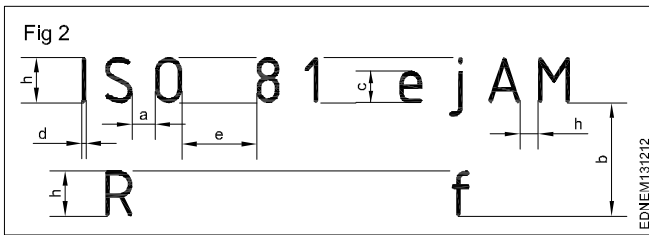

Lettering

Procedure

- 1 Print 10 mm single stroke capital letters and numerals in vertical style using either scale or set-square and by freehand. (Fig 1)

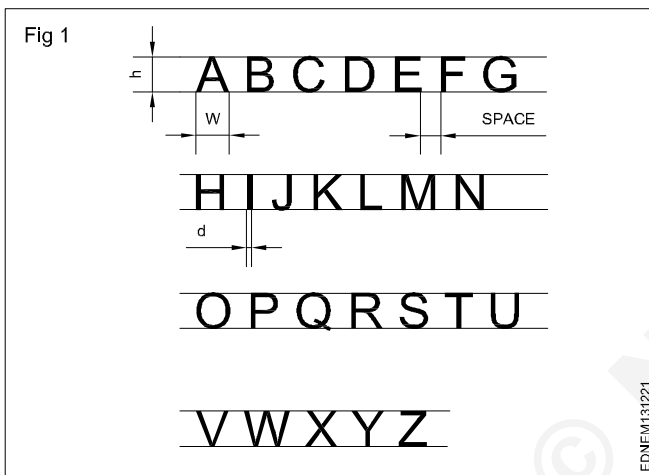

- Draw horizontal parallel lines (thin lines) of 10 mm distance.

10 mm distances denote the height of the letter.

- Mark the width of the letters recommended by BIS (IS:9609-1983)

The width of different letters in terms of 'd' is as follows: 'd' indicates stroke thickness i.e d: h/ 10.

Width (W)	Capital letters
1	I
4	J
5	C, E, F, L
6	B, D, G, H, K, N, O, P, R, S, T, U & Z
7	A, M, Q, V, X, Y
9	W

For curved letters use a smooth freehand curve.
Print straight line letters using either scale or set-squares.
To maintain the uniform thickness of the line, use a conical point soft grade pencil and avoid too much sharpness.
Guidelines of both top and bottom should always be drawn with a sharp pencil.

Numerals 2.1 (Fig 2)

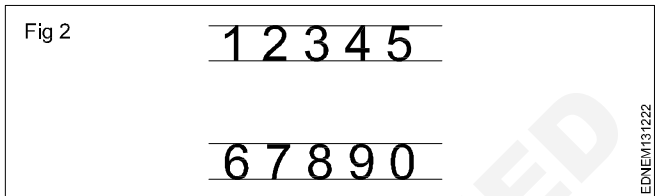

- Follow the same procedure of letters.
- 'h' is height of numerals and 'd' is the stroke thickness.
- Width of numerals in terms of 'd' is as follows shown in square grid (Fig 3).

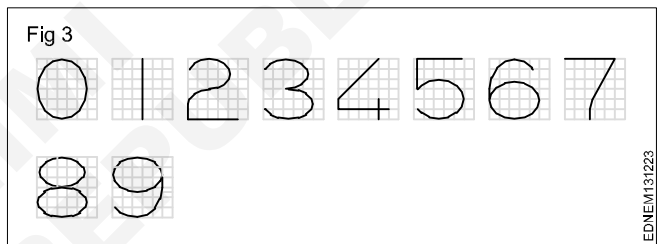

- 2 Print 10 mm single stroke capital letters and numerals in inclined style (Fig 4).



Practice the following lettering exercises in A3/A4 paper as per the given ratio

1 Single stroke inclined letters of ratio 7:6, 7:5, 7:4, 7:3, 7:1 (Fig 5)

Fig 5



SINGLE STROKE INCLINED LETTERS

EDNEM131225

2 Single stroke vertical letters of ratio 7:6, 7:5, 7.4, 7:3, 7:1 (Fig 6)

Fig 6

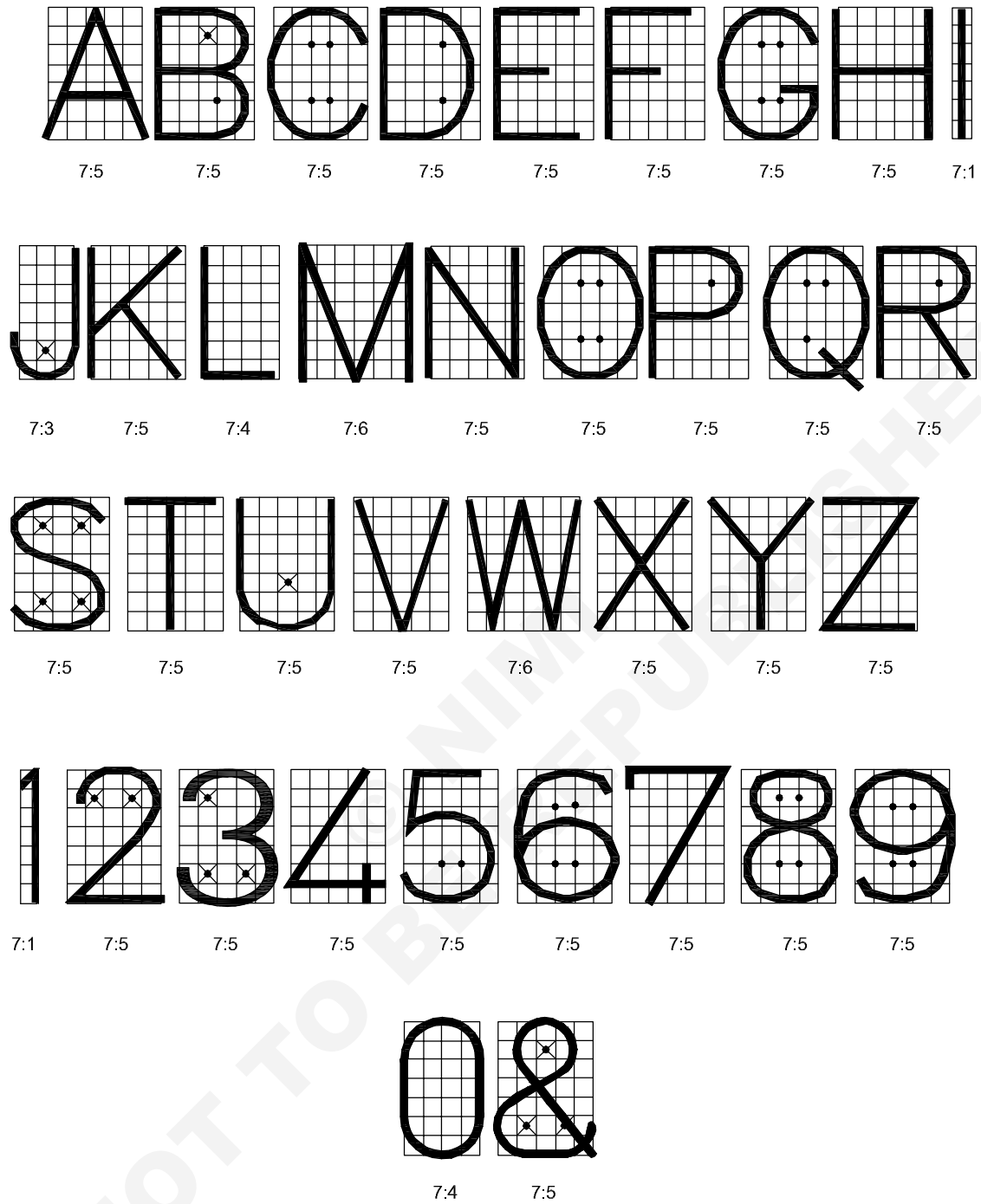

SINGLE STROKE VERTICAL LETTERS









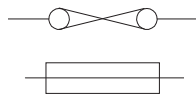

EDNEM131226

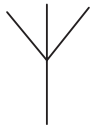

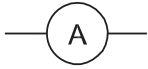
Symbolic representation - Different electronic symbols used in the related trades

Sign and symbols for Electronic group trades

S.No.	Description	Symbol
1	D.C.	
2	A.C.	
3	Positive	
4	Negative	
5	Single Phase A.C. 50 Hz	
6	Three Phase A.C., 50 Hz	
7	A.C. / D.C.	
8	Earth	
9	Cell	
10	Battery	

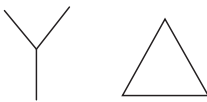
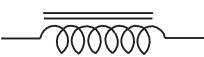
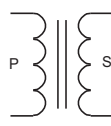
S.No.	Description	Symbol
11	Single pole single throw switch	
12	Push-button switch	
13	Energy meter	
14	Alternator	
15	Generator	
16	D.C. Motor	
17	A.C. Motor Single phase	
18	Capacitor: Fixed, variable	
19	Electrolytic Capacitor	
20	Two-way switch	

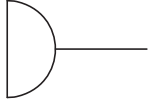
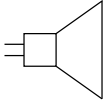
S.No.	Description	Symbol
21	Fuse: ordinary cartridge	
22	Socket 2 pin, 3 pin	
23	Aerial / Antenna	
24	Voltmeter	
25	Ammeter	
26	Ohm Meter	
27	Watt Meter	
28	Lamp	
29	Relay	
30	Buzzer	
31	Connections: star, Delta	
32	Choke	
33	Transformers	

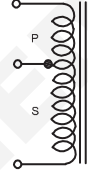
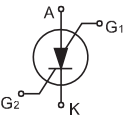
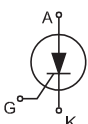
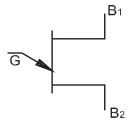
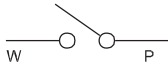
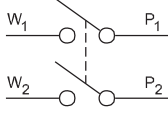
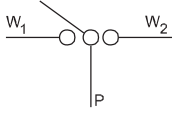
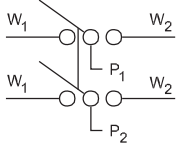
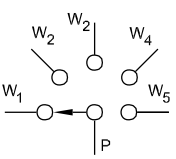
S.No.	Description	Symbol
34	Carbon microphone	
35	Loudspeaker	
36	Diode	
37	Auto transformer	
38	Silicon Bilateral switch (SBS)	
39	SCR	
40	UJT	
41	SPS T switch	
42	DPS T switch	
43	SPD T switch	
44	DPD T switch	
45	Single Pole 5 way rotary switch	

S.No.	Description	Symbol
46	Piezoelectric crystal	
47	Diac	
48	Varactor diode	
49	Zener diode	
50	TRIAC	
51	PNP transistor	
52	NPN transistor	
53	FET N-channel	
54	FET P-channel	
55	LED diode	

S.No.	Description	Symbol
56	Photo voltaic cell	
57	AND Gate	
58	NAND Gate	
59	OR Gate	
60	NOR Gate	
61	NOT Gate	
62	EX-OR Gate	
63	EX-NOR Gate	
64	T Flip-Flop	
65	Operational amplifier	
66	Analog multimeter	

Reading of electronic circuit diagram

Electronics Circuit drawing

A stable multi-vibrator using IC 555 (Fig 1)

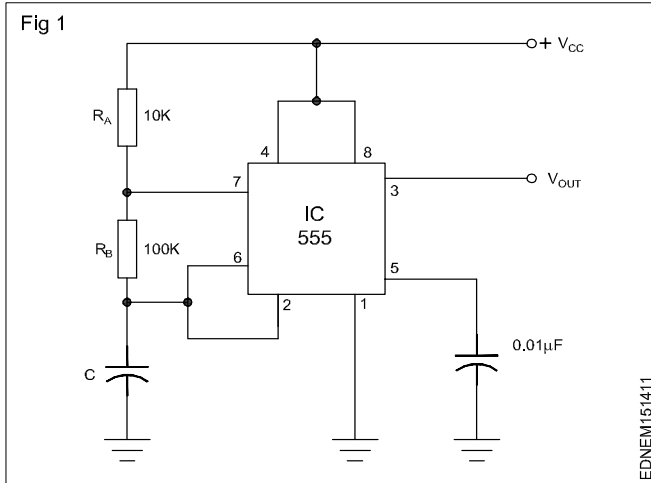

Read and write the Following (Fig 1)

- 1 What is the function of the circuit diagram?
- 2 Which pin is connected to output?
- 3 What is threshold voltage?
- 4 How to calculate the time constant?
- 5 What is the purpose of 'C' in the circuit?

Digital to Analog converter (Fig 2)

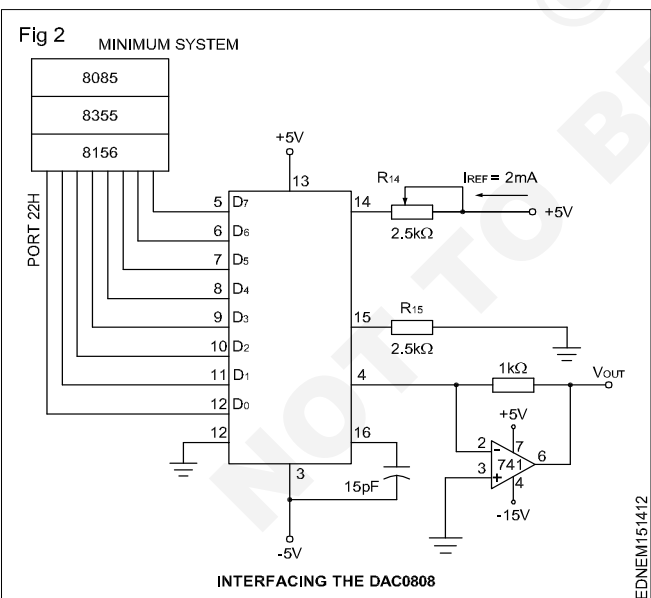

Read and write the Following (Fig 2)

- 1 What is the function of DAC-0808?
- 2 What is the output current setting time of 0808?
- 3 What is the direct replacement of DAC 0808?
- 4 How to minimize the size?
- 5 What are the application of DAC 0808?

8-line multiplexer using 74LS151 (Fig 3)

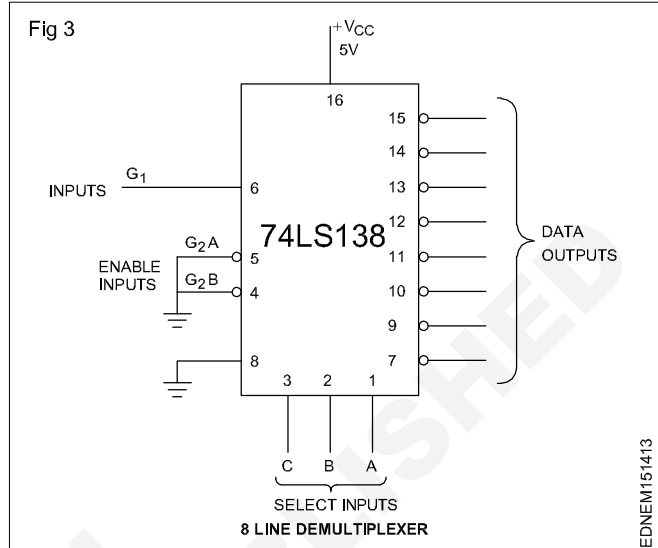

Read and write the Following (Fig 3)

- 1 What is the name of diagram?
- 2 What is the V_{CC} for 74LS138 IC?
- 3 What is the functions of Demultiplexer?
- 4 What are the application of IC 74LS138?
- 5 Explain the data transmission?

NOT Gate circuit using transistor (Fig 4)

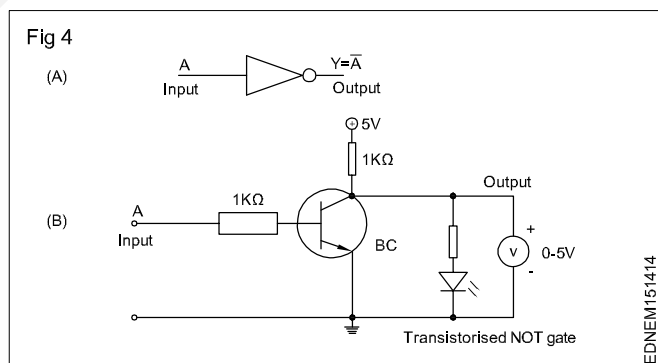

Read and write the Following (Fig 4)

- 1 What is the output of NOT gate?
- 2 How to test the NOT gate?
- 3 What is the V_{CC} voltage for the circuit?
- 4 What will happen if increase more voltage?
- 5 What is the meaning of a small circle (bubble) used in the NOT gate symbol?

Light-Controlled switching amplifier (Fig 5)

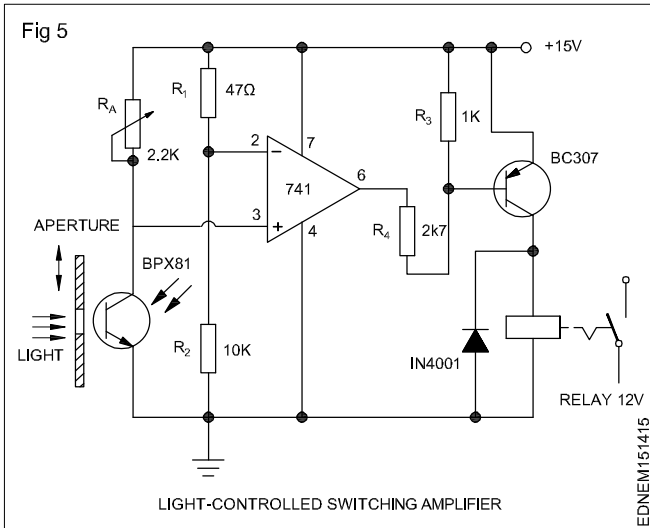

Read and write the Following (Fig 5)

- 1 Which IC is used in the circuit diagram?
- 2 What is the purpose of BPX81?
- 3 Explain Aperture?
- 4 What is the equivalent of BC307?
- 5 What is the cause of removing the IN4001 in this circuit?

Optocoupler Types (Fig 6)

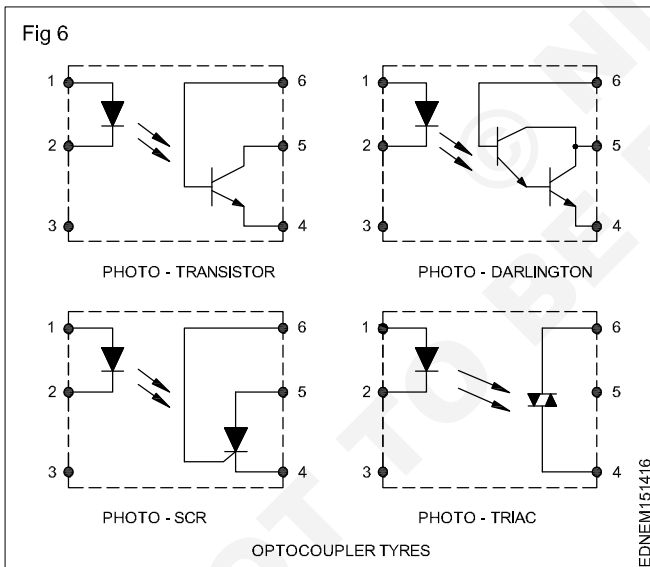

Read and write the Following (Fig 6)

- 1 What is the other name of Optocoupler?
- 2 What are the several types of Optocoupler?
- 3 Explain the function of photo transistor?
- 4 What are the application of Opto-isolators?
- 5 What are the different medium of components used in Optocoupler?

Simple Lamp dimmer circuit (Fig 7)

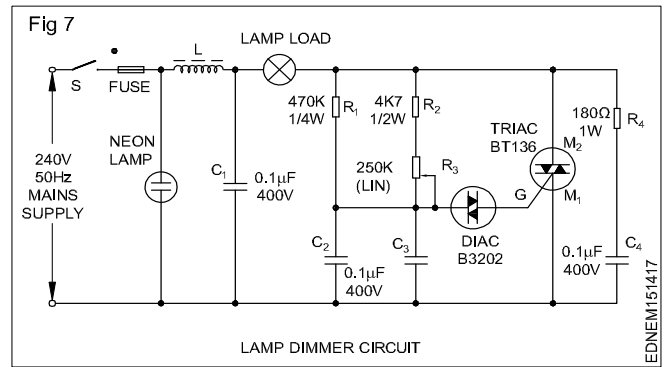

Read and write the Following (Fig 7)

- 1 Which control device is used in a simple lamp dimmer circuit?
- 2 Which technique is used to control the conduction angle of TRIAC?
- 3 Which pulse is given to gate of TRIAC?
- 4 What is the break over voltage of DIAC?
- 5 What is the purpose of R₃ potentiometer?

Fixed gain a.c voltage amplifier (Fig 8)

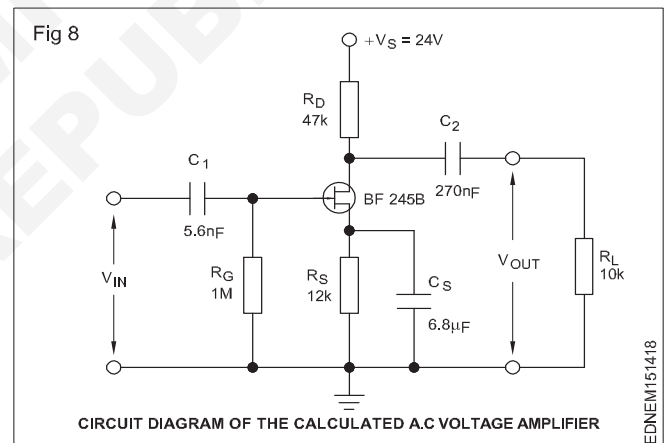

Read and write the Following (Fig 8)

- 1 Why C₁ (5.6nf) is connected in this circuit?
- 2 What is the V_{CC} voltage used in this circuit?
- 3 Which power electronic component is used?
- 4 Why 10K resistor is used in the output?
- 5 What is the function of C₂ 270nF?

Hartley Oscillator (Fig 9)

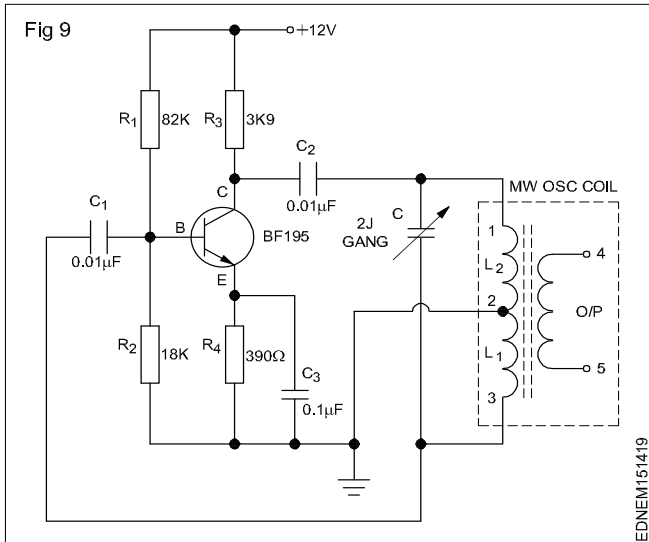

Read and write the Following (Fig 9)

- 1 What is the oscillator frequency range?
- 2 Which winding output is taken?
- 3 What is the E_{CC} for the oscillator circuit?
- 4 What is the name of oscillator circuit?

Class - B push-pull amplifier (Fig 10)

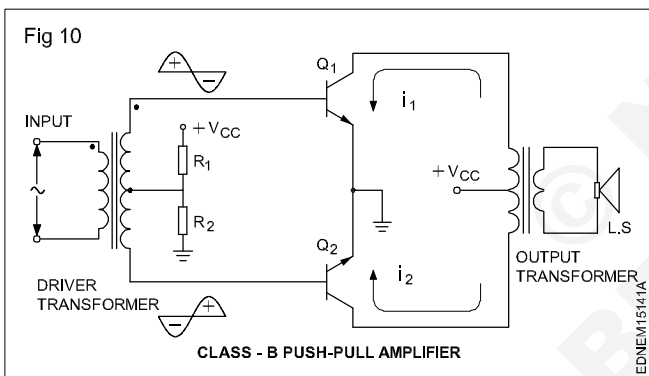

Read and write the Following (Fig 10)

- 1 Which type of coupling is used in this diagram?
- 2 What is the purpose of output transformer?
- 3 What is the advantage of push-pull amplifier?
- 4 Explain the cross over distortion?

Dual regulated power supply (Fig 11)

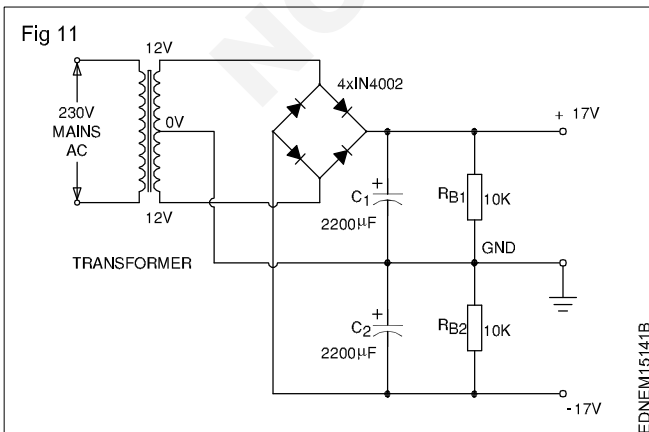

DC supply using ICs 7812 and 7912 (Fig 12)

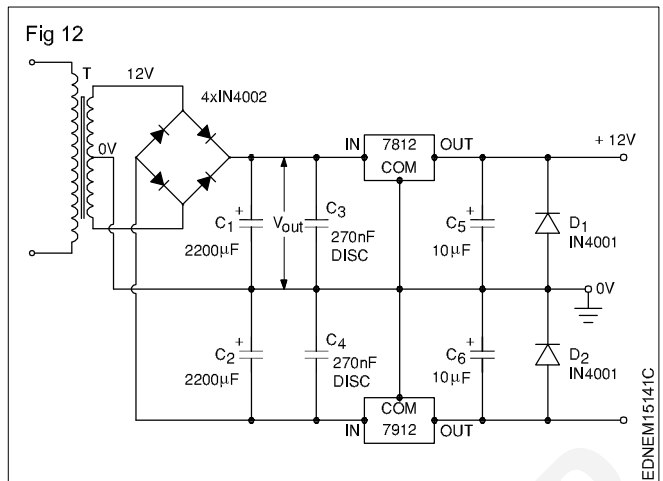

DC supply using ICs 7812 and 7912 with load (Fig 13)

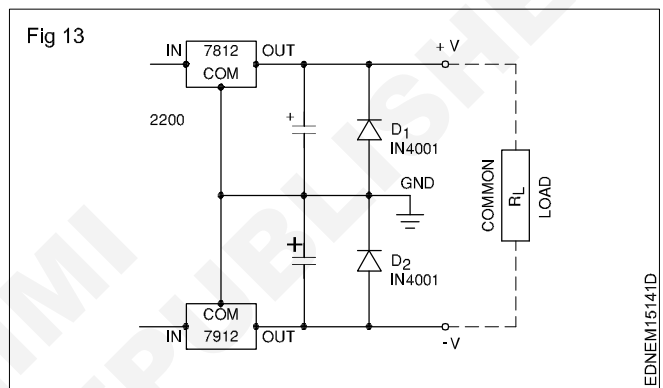

Circuit uses a few by pass capacitors and protection diodes (Fig 14)

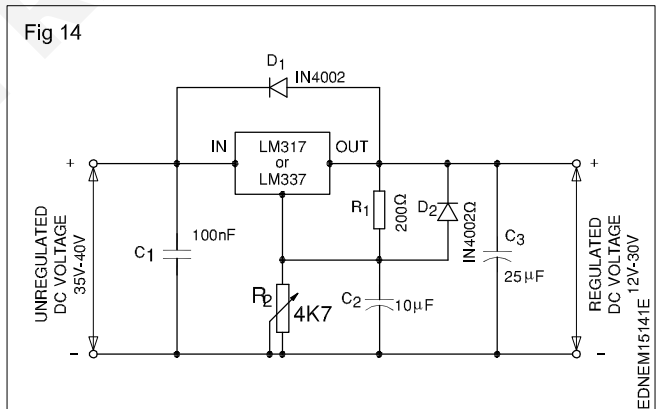

Read and write the Following (Fig 11 to 14)

- 1 Which type of transformer is used in Fig 11?
- 2 What is the purpose of 2200µF capacitor? (Fig 11)
- 3 Which type of power supply is used? (Fig 11)
- 4 What is the output voltage? (Fig 12)
- 5 Why two diodes are connected? (Fig 13)
- 6 What is the use of LM 317? (Fig 14)
- 7 Can we replace LM 317 instead of LM 337? (Fig 14)
- 8 What is the purpose of 4K7 potentiometer? (Fig 14)

Positive Voltage Regulator using IC 723 (Fig 15)

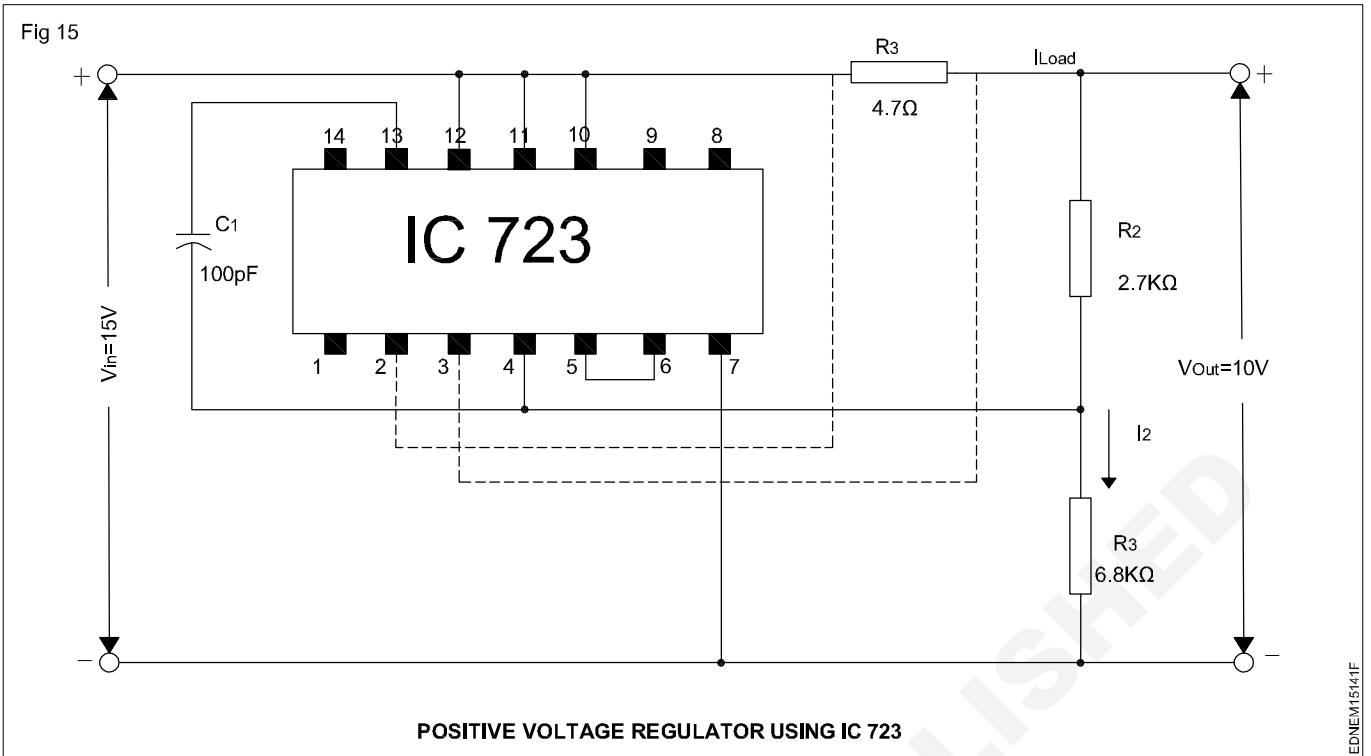

In Fig 16, when the resistance of the POT is set to 0, COM is grounded and hence output will be 12V. As the set value of pot increases the output voltage also increases.

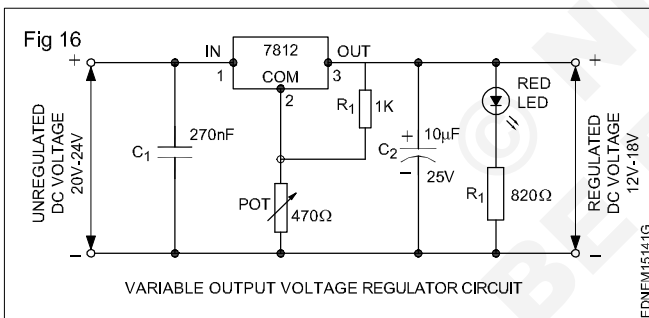
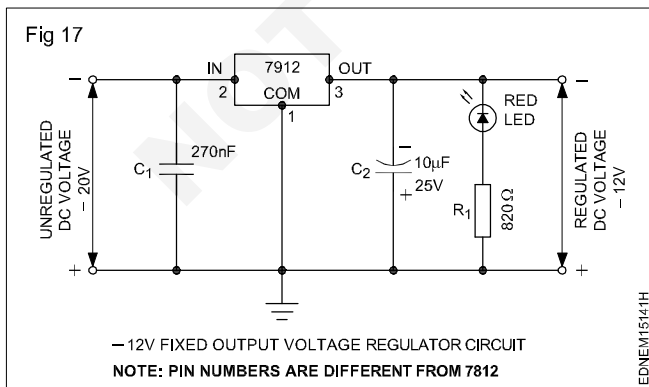
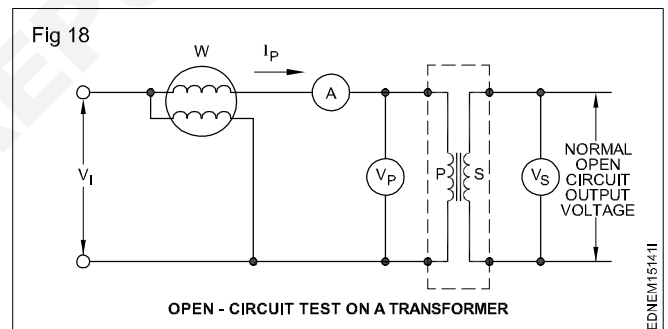

Fig 17 shows a negative voltage regulator using 7912. The working of this circuit is similar to that of except that it is a negative voltage regulator and hence the voltage at pin no.3 of the IC will be -12volts.



No-load test or open circuit test (O-C test)

Fig 18 shows the circuit arrangement for O-C test on a transformer.



Full load test or short circuit test (S-C test)

Fig 19 shows the circuit arrangement for S-C test on a given transformer.

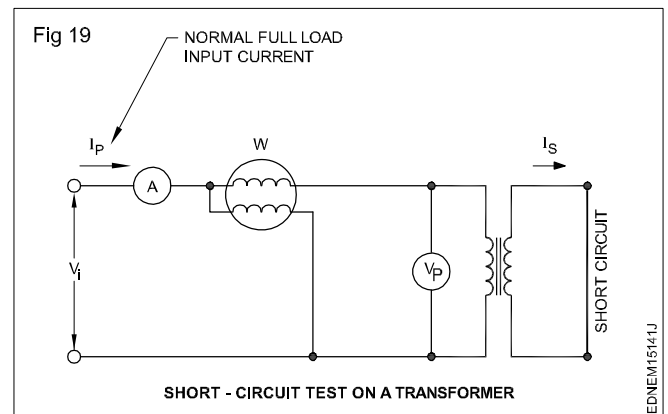

Connection in series grouping: Series grouping of capacitors, as shown in Fig 20 is analogous to the connection of resistances in series or cells in series.

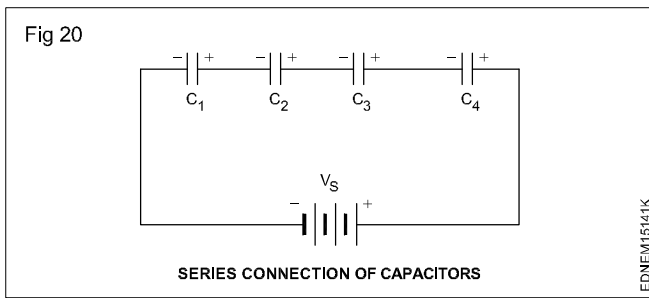

Connection of parallel grouping: Parallel grouping of capacitors is shown in Fig 21 and is analogous to the connection of resistance in parallel or cells in parallel.

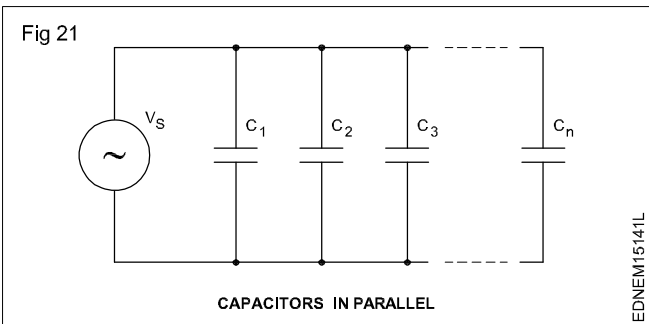

Logic probe (Fig 22)

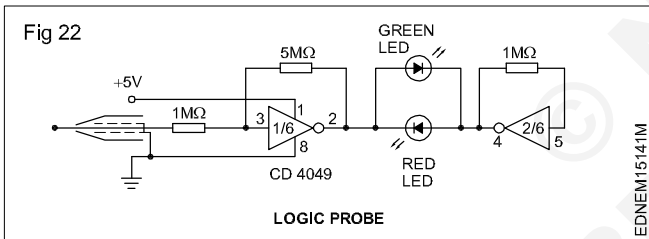

1's compliment circuit (Fig 23)

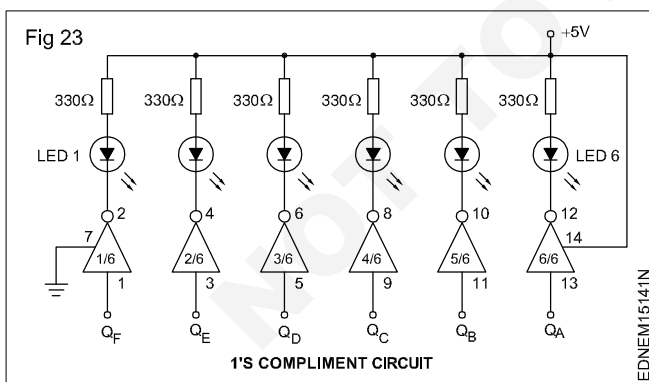

Light-controlled switching amplifier (Fig 24)

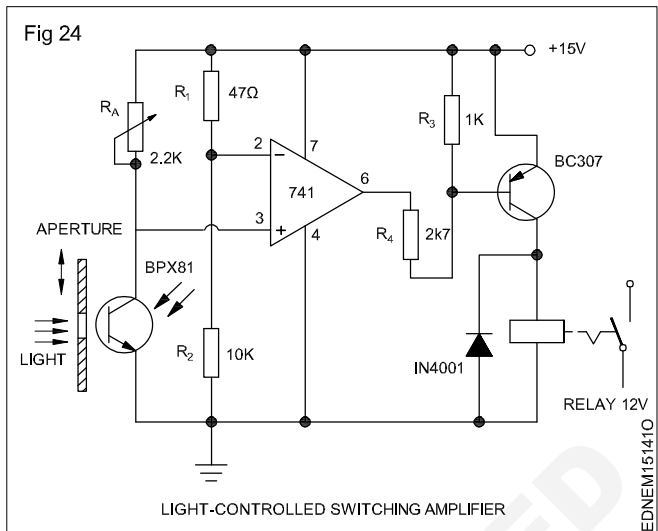

Light-controlled amplifier with phototransistor (Fig 25)

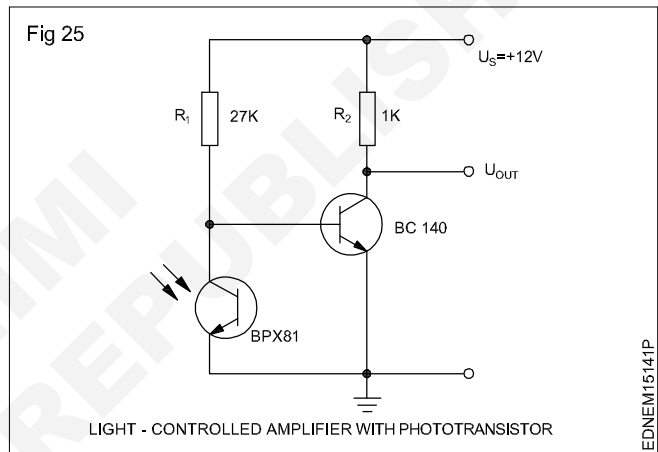

Illumination Photometer (Fig 26)

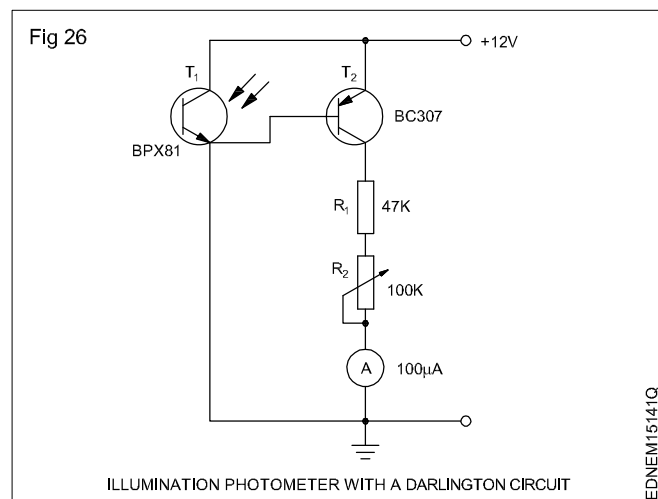

Mono stable multivibrator (Fig 27)

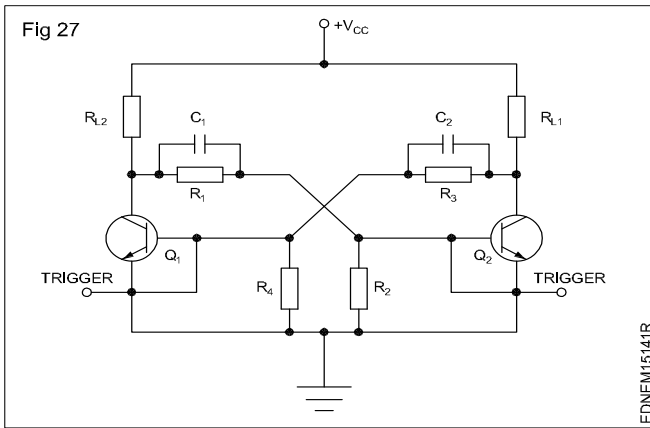

Hubs: Some networks require a central point of connection between media segments. These central points are referred to as hubs as shown in Fig 28.

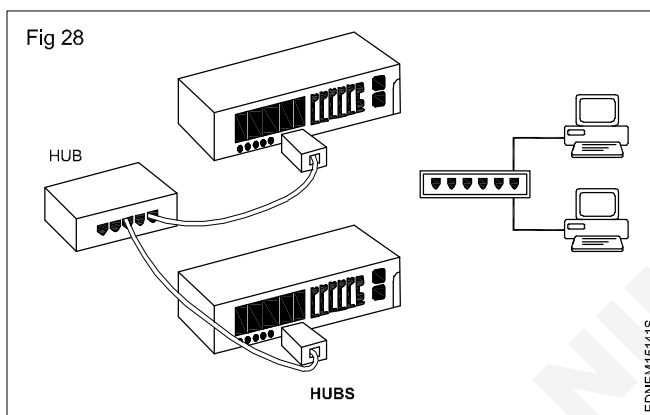

Feedback and Error Amplification (Fig 29)

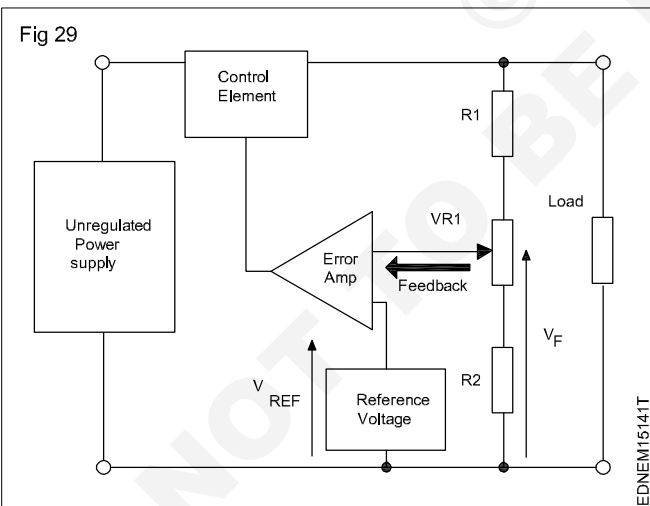

Read and write the Following (Fig 15 to 29)

- 1 What type of regulator is IC 723? (Fig 15)
- 2 How many pins are in IC 723? (Fig 15)
- 3 What are the output voltage available? (Fig 16)
- 4 How to find the type of regulator? (Fig 17)
- 5 What is the name of the circuit? (Fig 18)
- 6 Name the circuit? (Fig 19)

- 7 What is the total capacitance value? (Fig 20)
- 8 How to find the total value of capacitance? (Fig 21)
- 9 What is the purpose of hub? (Fig 28)
- 10 What is the purpose of feedback? (Fig 29)
- 11 What is reference voltage? (Fig 29)
- 12 What is the function of error amplifier? (Fig 29)
- 13 What is the use of logic probe? (Fig 22)
- 14 What is the purpose of 1's compliment? (Fig 23)
- 15 What is linear characteristics of photometer? (Fig 26)
- 16 What is the name of the circuit? (Fig 26)
- 17 What is the use of photometer? (Fig 26)
- 18 What is the name of the circuit diagram? (Fig 27)
- 19 What is the use of monostable multivibrator? (Fig 27)
- 20 What is the use of BPX81? (Fig 26)
- 21 Differentiate IC 7812 and IC 7912? (Fig 16&17)
- 22 What is control element? (Fig 29)

Capacitors in Series (Fig 30)

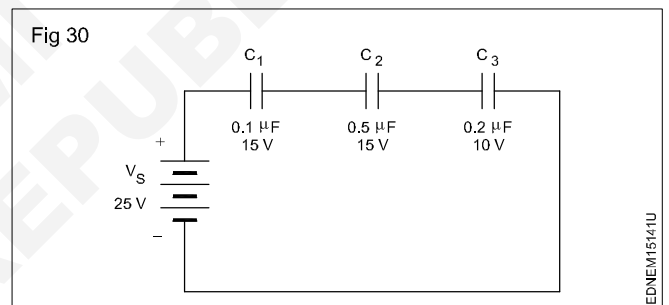

Read and write the Following (Fig 30)

- 1 Find the total capacitance?
- 2 Find the name of group?
- 3 What is the voltage drop across C₁?
- 4 What is the voltage drop across C₂ & C₃?

Inductance in Series (Fig 31)

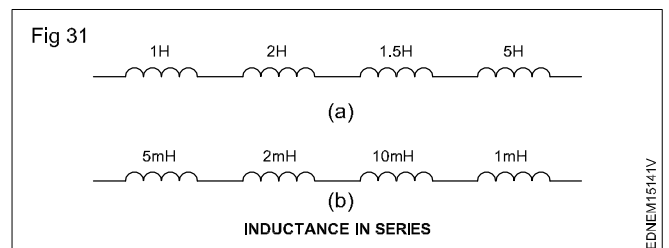

Read and write the Following (Fig 31)

- 1 What is the total inductance? (Fig 31a)
- 2 What is the total inductance? (Fig 31b)

Inductance in Parallel (Fig 32)

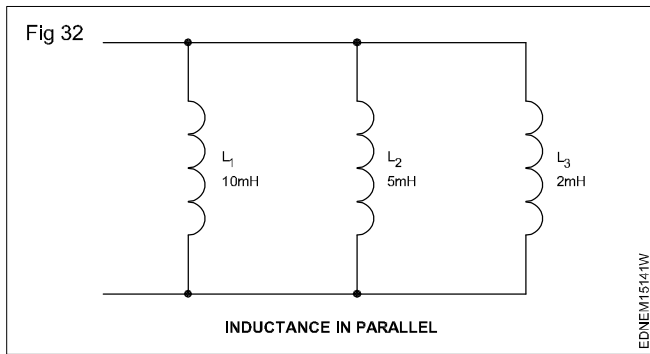

Read and write the Following (Fig 32)

- 1 Find the group of connections?
- 2 How to find the total inductance in the circuit?

Multi-range Ampere meters (Fig 33)

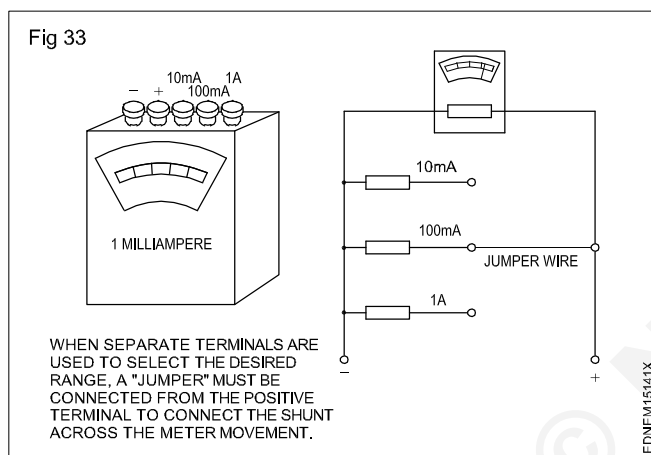

Read and write the Following (Fig 33)

- 1 Why range switch is used in the circuit?

Range of Ammeter (Fig 34)

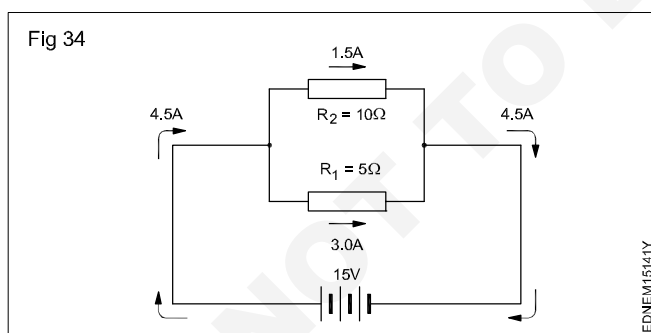

Read and write the Following (Fig 34)

- 1 What is the range of the circuit?
- 2 What is the total current flows through the circuit?

Three Phase Wattmeter (Fig 35)

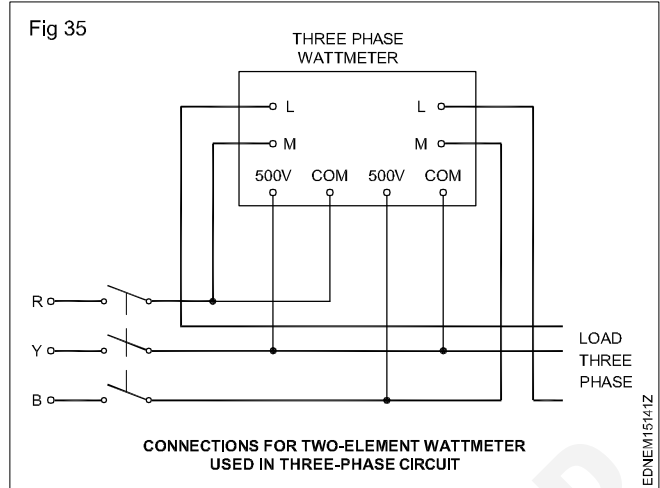

Read and write the Following (Fig 35)

- 1 How to measure voltage in 3 phase?
- 2 How to connect the three phase wattmeter?

3 Phase Energy meter (Fig 36)

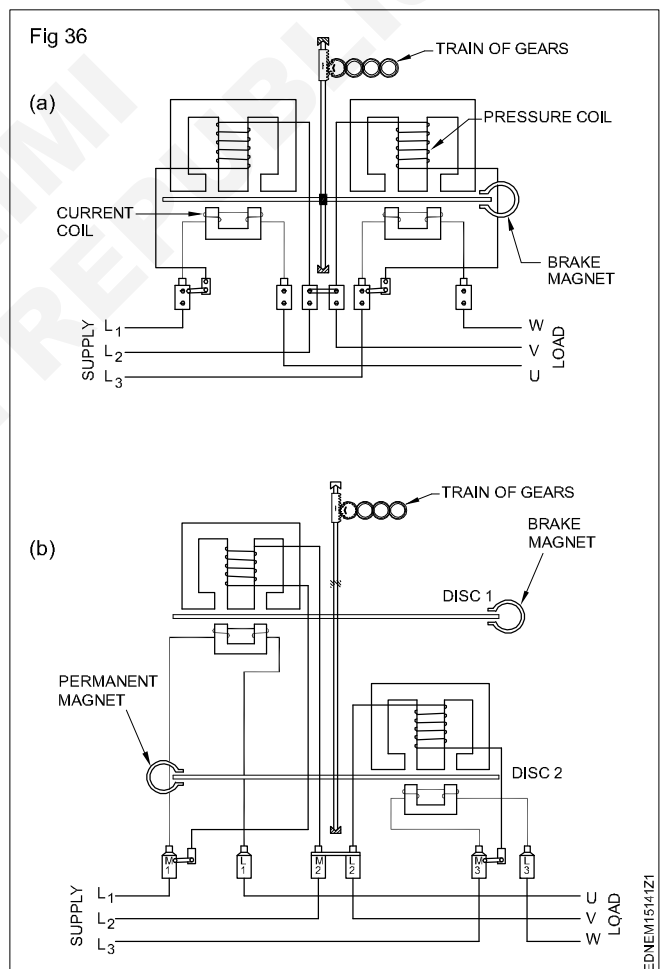

Read and write the Following (Fig 36)

- 1 What will happen if the link L_1 is open?
- 2 What will happen if the brake magnet is not present?

Crow Bar Circuit (Fig 37)

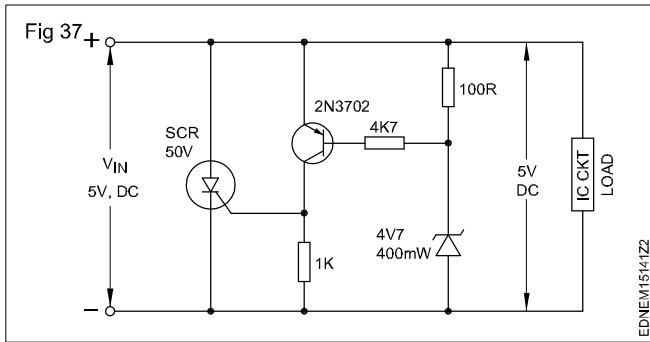

Read and write the Following (Fig 37)

- 1 What is the use of crow bar circuit?
- 2 Why SCR is used in the diagram?

Master Slave Flip-flop (Fig 38)

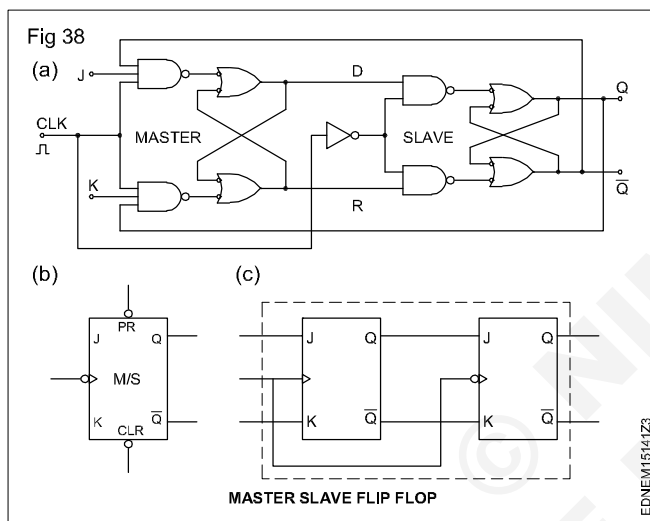

Read and write the Following (Fig 38)

- 1 What is the use of Master slave Flip-flop?

LC Oscillator (Fig 39)

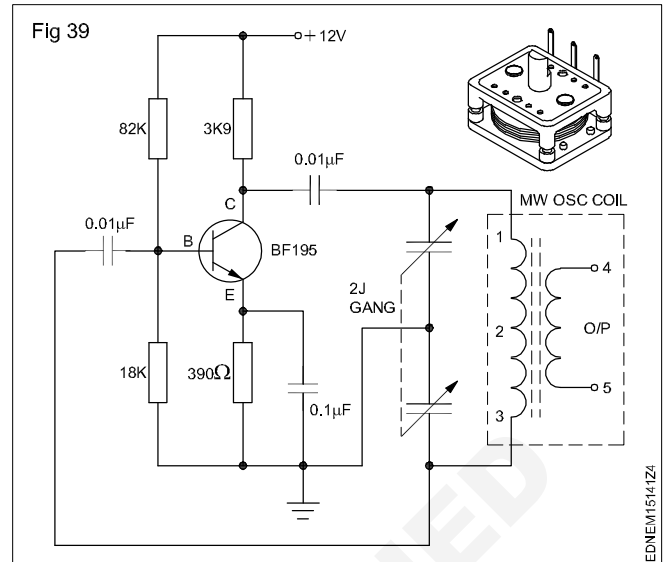

Read and write the Following (Fig 39)

- 1 What is the purpose of LC oscillator?

Zener Shunt regulator (Fig 40)

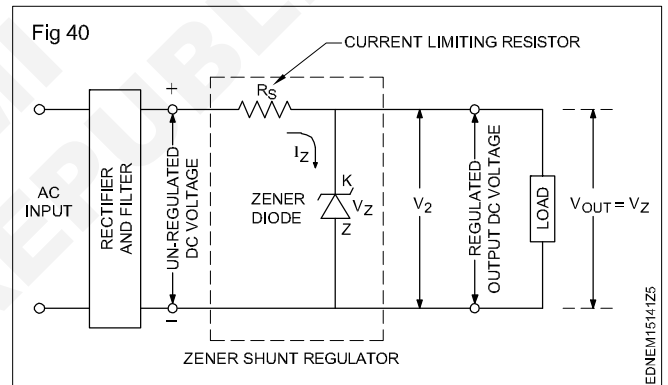

Read and write the Following (Fig 40)

- 1 What is the advantage of Zener shunt regulator?

Reading of electronic layout drawing

Installation layout diagram of DTH

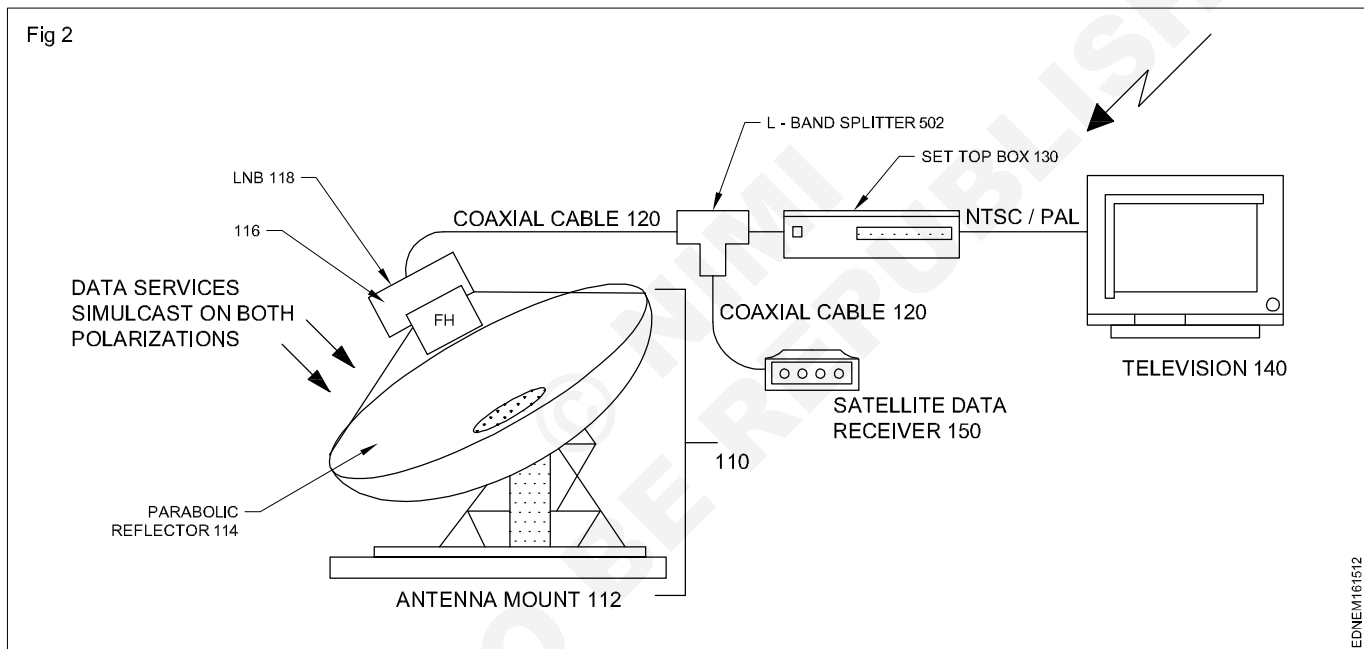
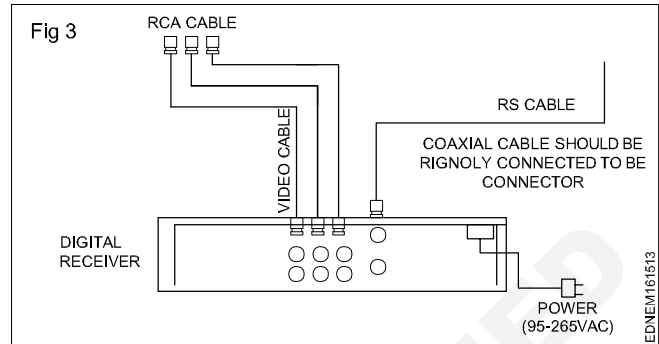
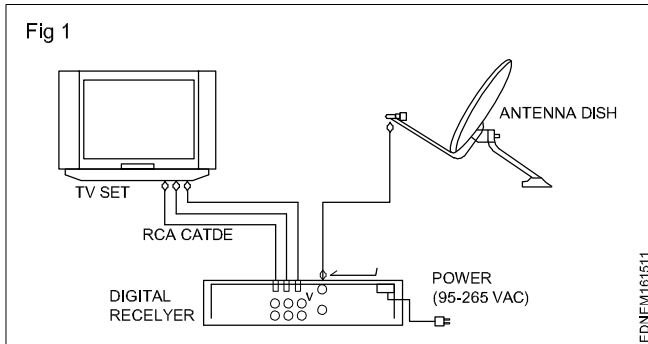

Read and write the Following (Fig 1,2 & 3)

- 1 Which type of connector is used to connect the TV set and digital receiver in the Layout diagram of DTH? (Fig 1, 2 &3)
- 2 What is the purpose of the Digital receiver?
- 3 What is polarization?
- 4 Why parabolic reflector is used in DTH system?
- 5 Why 'L' band splitter is used?

Layout diagram of DOL starter with protective devices (Fig 4)

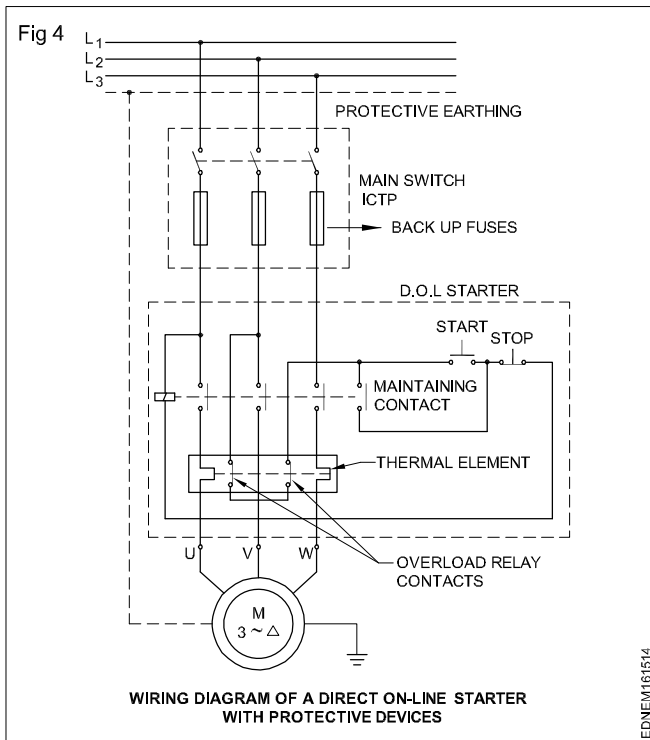

Read and write the Following (Fig 4)

- 1 What is the purpose of DOL starter?
- 2 How to maintain the thermal element?
- 3 How to minimize the overload?
- 4 Explain the working function of DOL starter?
- 5 What is the advantage of Earthing?

Bridges (Fig 5)

Bridges: A bridge extends the maximum distance of your network by connecting separate network segments. Bridges selectively pass signals from one medium segment to another as in Fig 5.

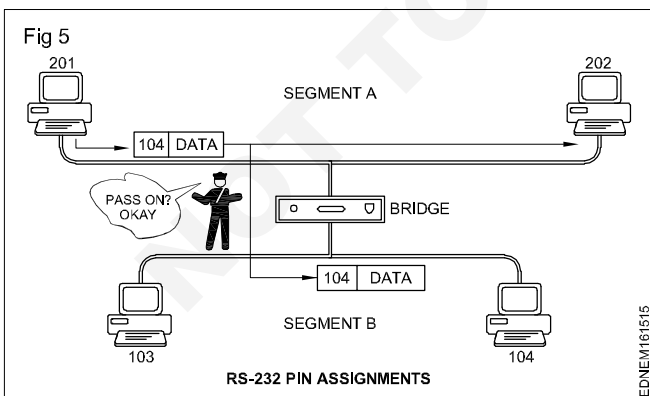

Read and write the Following (Fig 5)

- 1 Name the layout diagram?
- 2 What is the use of BRIDGE?
- 3 How signals are received and discarded?
- 4 Which media used to send signals from segment A to segment B?

Service connection for homes (Fig 6)

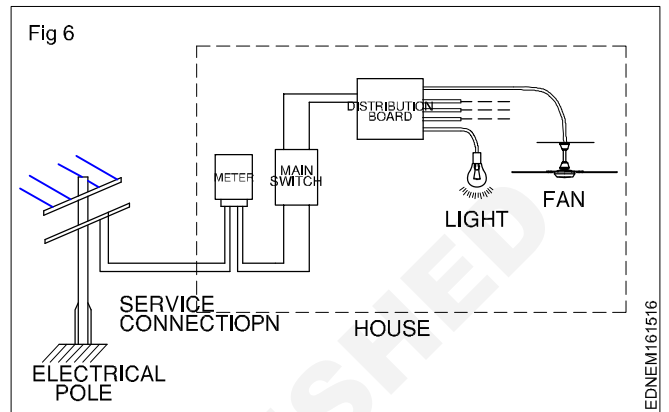

Integrated circuit layout (Fig 7)

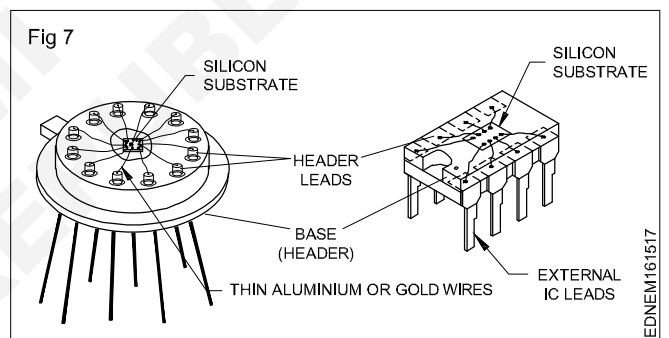

Read and write the Following (Fig 6 to 7)

- 1 How to make a service connection layout?
- 2 What is the range of domestic voltage?
- 3 What is header leads?
- 4 What is the purpose of silicon substrate use?
- 5 Why thin aluminium or gold wires used while edging ICs?
- 6 What is photolithographic process?

Basic block diagram of an electronic thermostat (Fig 8)

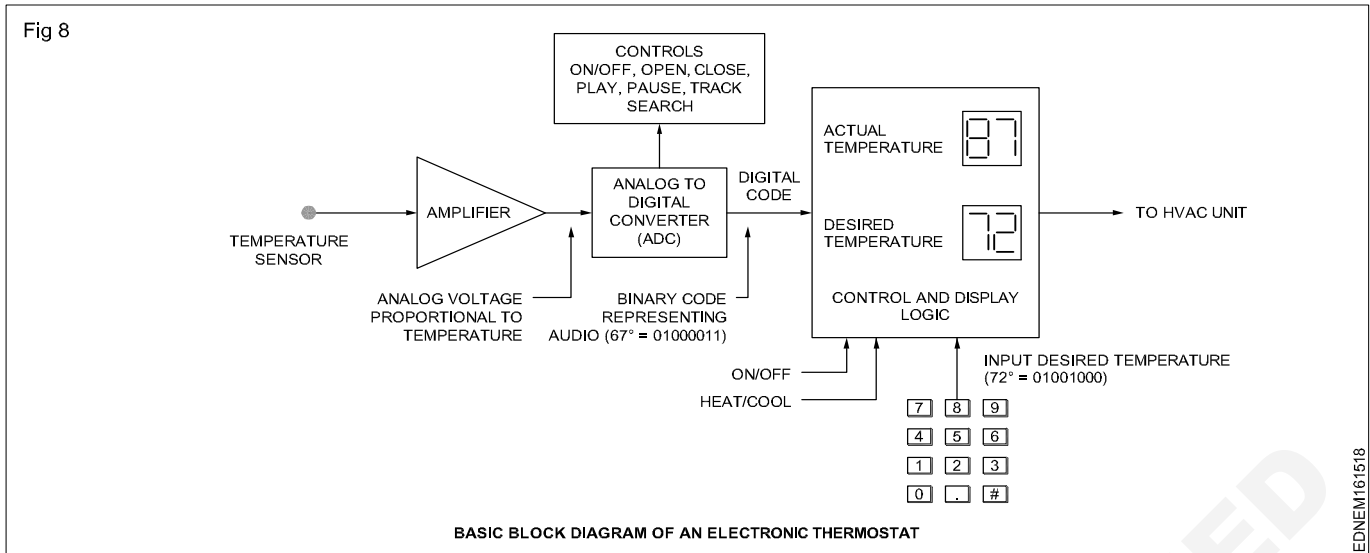

Block diagram of 8-bit microprocessor compatible analog to digital converters (Fig 9)

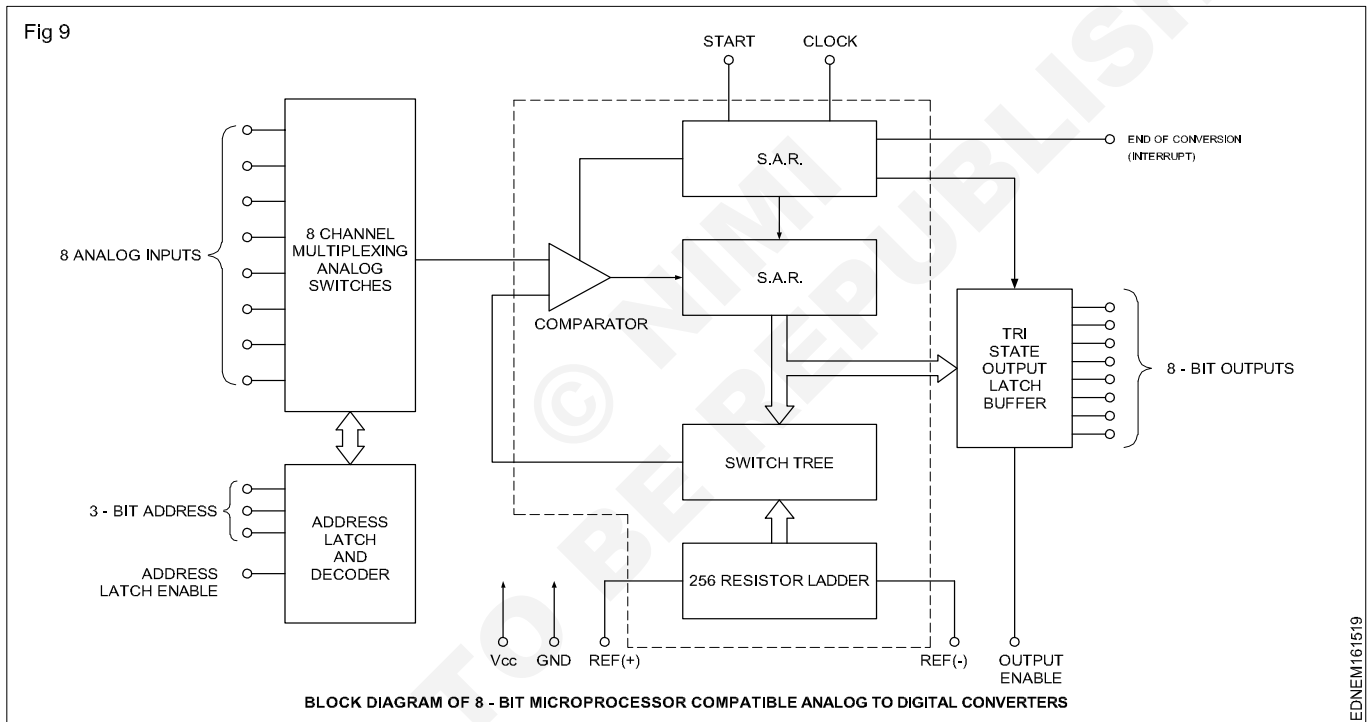

4 bit ripple counter (Fig 10)

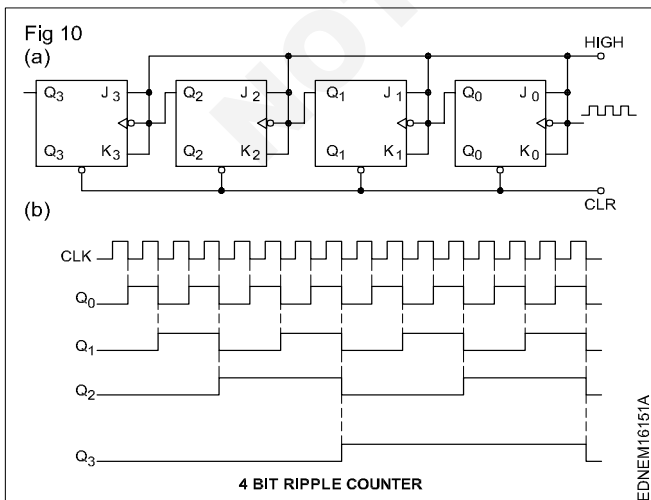

Read and write the Following (Fig 8 to 10)

- 1 What is the use of electronic thermostat?
- 2 Why temperature sensor used?
- 3 How electronic thermostat works?
- 4 How analog to digital converter works?
- 5 What is the use of comparator?
- 6 What is the use of decoder?
- 7 How S.A.R works?
- 8 How many bit outputs are available? (Fig 9)
- 9 Name the diagram? (Fig 10)
- 10 How ripple counter works? (Fig 10)
- 11 What is the purpose of switch tree section? (Fig 9)

Induction type energy meter (Fig 11)

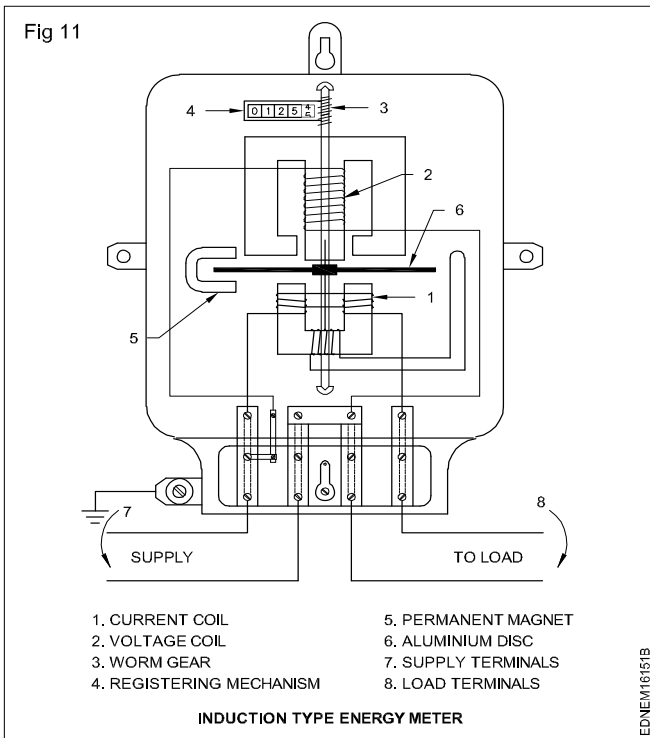

Read and write the Following (Fig 11)

- 1 What is the use of induction type energy meter?
- 2 Why worm gear is used?
- 3 What is the use of current coil?
- 4 What is the use of voltage coil?

Block diagram of a Driven inverter (Fig 12)

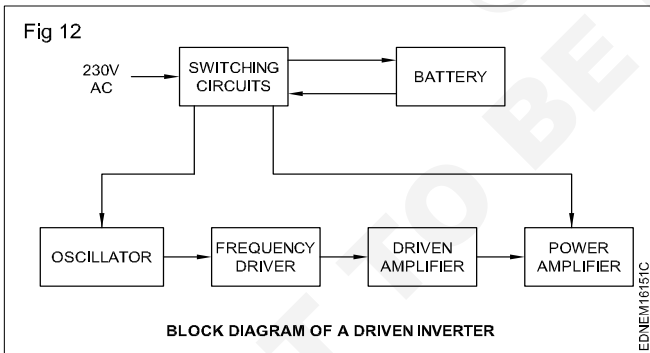

IC 555 Timer (Fig 13)

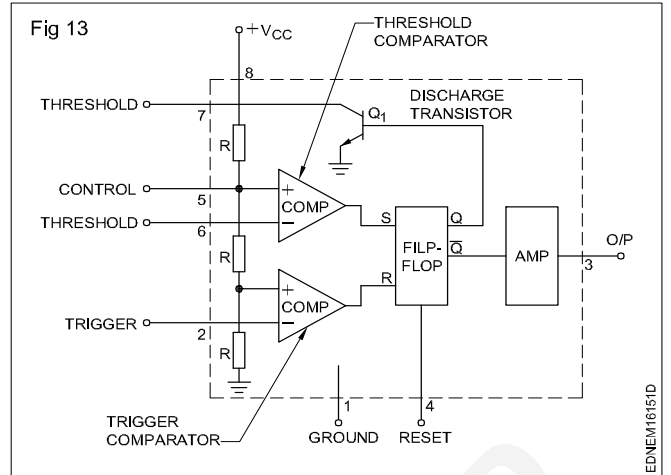

Block diagram of SMPS (Fig 14)

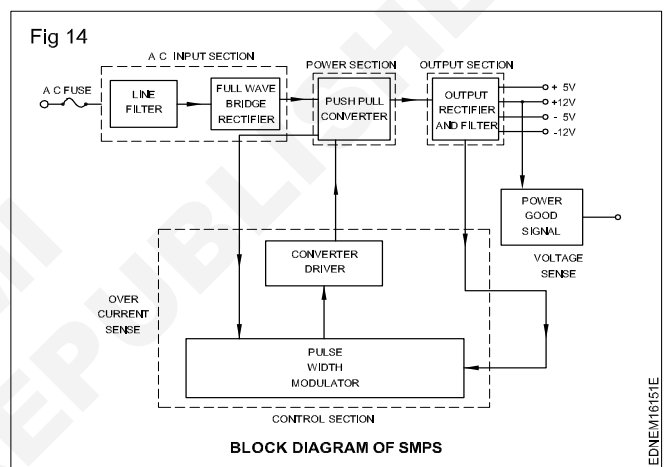

Read and write the Following (Fig 12 to 14)

- 1 What is the function of oscillator? (Fig 12)
- 2 What is the use of driven inverter? (Fig 12)
- 3 Explain the function of 555 timer circuit? (Fig 13)
- 4 Why comparator is used in the diagram? (Fig 13)
- 5 How many section are in SMPS circuit? (Fig 14)
- 6 Why power good signal is essential? (Fig 14)
- 7 Which type of modulator is used? (Fig 14)
- 8 What is the use of line filter? (Fig 14)